

A. 主体関係 / Machine body / Maschinengehäuse / Corps de la machine / Cuerpo de la máquina

Notes sur l'utilisation de ce manuel

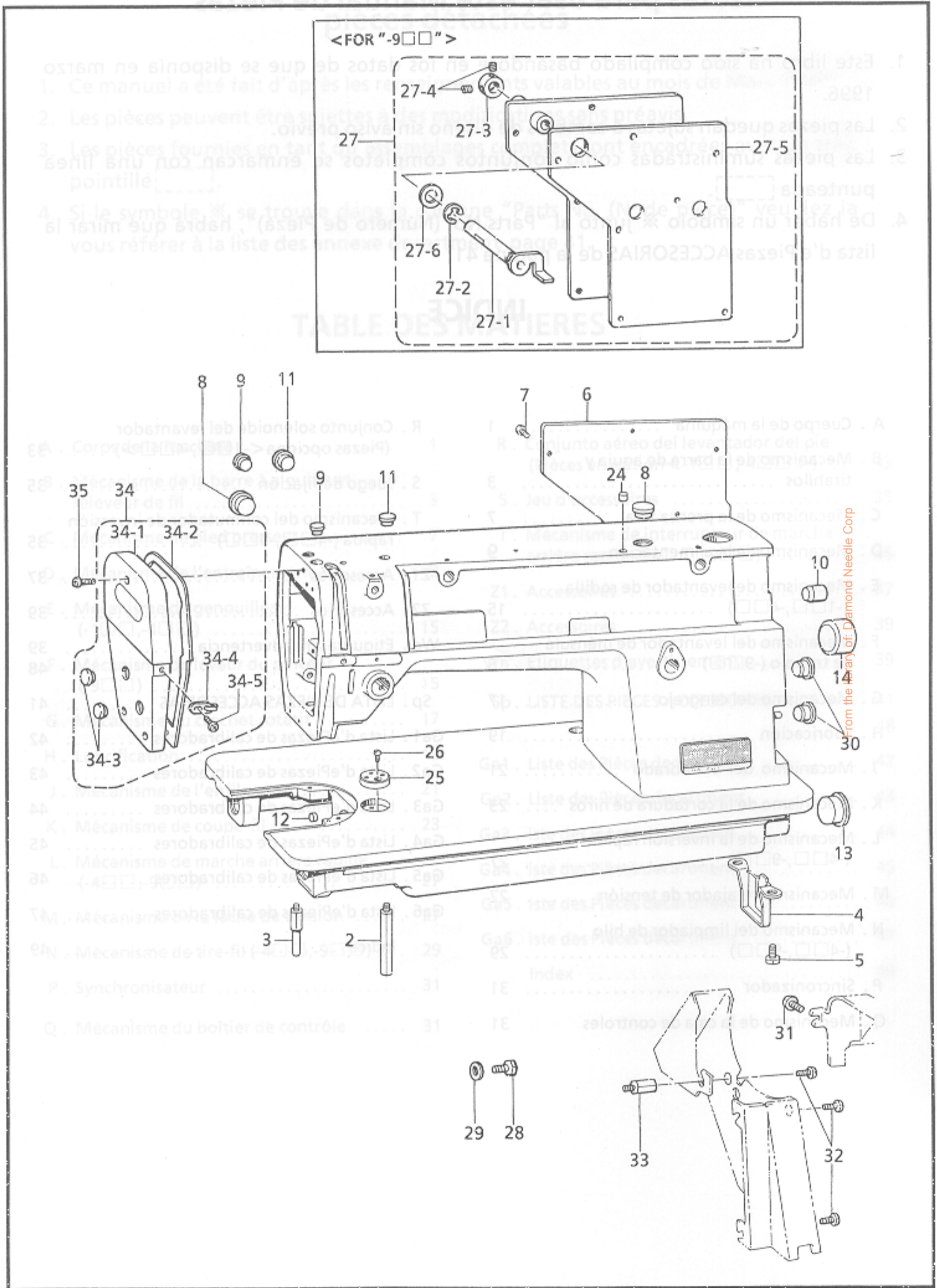

From the library of: Diamond Needle Corp

A. 主体関係 / Machine body / Maschinengehäuse / Corps de la machine / Cuerpo de la máquina

REF.NO.	CODE	Q'TY	ヒンメイ	NAME OF PARTS	RM
2	104829121	1	キヤクチュウL	BED LEG (L)	
3	104830121	1	キヤクチュウS	BEL LEG (S)	
4	118672021	1	ポンプカバー	PUMP COVER	
5	140704021	2	ボルト7.14	BOLT, SM7.14	
7	062681012	7	ナベコ437-40X10	SCREW, PAN SM4.37-40X10	
8	104449009	2	ゴムセン15.5	RUBBER CAP, 15.5	
9	104450109	2	ゴムセン8	RUBBER CAP, 8	
10	104832009	1	ゴムセン10.7	RUBBER CAP, 10.7	
11	104821009	2	ゴムセン10.5	RUBBER CAP, 10.5	
12	142274009	1	ゴムセン4.2	RUBBER CAP, 4.2	
13	108520009	1	ゴムセン19.8	RUBBER CAP, 19.8	
14	104451009	1	ゴムセン23.9	RUBBER CAP, 23.9	
24	156217009	1	ゴムセン8.5	RUBBER CAP, 8.5	
25	S09621001	1	ジヨウギイタ	RULER PLATE	
26	062670612	1	ナベコ357-40X6	SCREW, PAN SM3.57-40X6	
29	100645023	1	ザガネ	WASHER	
30	104450109	2	ゴムセン8	RUBBER CAP, 8	
32	062760812	3	ナベコ595-28X8	SCREW, PAN SM5.95-28X8	
33	157969021	1	スタツド	STUD	
34	S36827021	1	メイタクミ	FACE PLATE ASSY	
34-1	S36828021	1	メイタ	FACE PLATE	
34-2	S35529020	1	メイタパツキン	FACE PLATE PACKING	
34-3	104449009	2	ゴムセン15.5	RUBBER CAP, 15.5	
34-4	S02617001	1	メイタイトアンナイ	FACE PLATE THREAD GUIDE	
34-5	060670612	1	バインド357-40X6	SCREW, BIND SM3.57-40X6	
35	062671012	3	ナベコ357-40X10	SCREW, PAN SM3.57-40X10	
6	S39560021	1	<FOR "-1□□,-4□□"> ガワイタ	FACE PLATE	
31	062680812	1	ナベコ437-40X8	SCREW, PAN SM4.37-40X8	
27	S16644102	1	<FOR "-9□□"> トウブデンジガワイタ	REAR COVER	
27-1	S32923001	1	オサエアゲジク	PRESSER BAR SHAFT	
27-2	048080342	1	トメワE8	RETAINING RING, E8	
27-3	110197001	1	セツトカラー	SET SCREW COLLAR	
27-4	153675001	2	アナトメネジ4.37	SET SCREW, SOCKET M4.37	
27-5	S28928020	1	ガワイタパツキン	REAR COVER PACKING	
27-6	025100132	1	ヒラザガネシヨウ10	WASHER, PLAIN S 10	
28	017681012	1	<FOR "BELT COVER"> ボルト4.37X10	BOLT, SM4.37X10	
29	100645023	1	ザガネ	WASHER	
7	S1481102	1	ニードルバー(DP)	NEEDLE BAR (DP)	
7	S14815021	1	ニードルバー(DP)	NEEDLE BAR (DP)	
8	100265034	1	ニードルDBX1(#11)	NEEDLE DBX1 (#11)	
8	107401811	1	ニードルDPX5(#11)	NEEDLE DPX5 (#11)	
8	100265034	1	ニードルDBX1(#14)	NEEDLE DBX1 (#14)	
8	107401811	1	ニードルDPX5(#14)	NEEDLE DPX5 (#14)	
2	S37813021	1	ニードルDPX5(#14)	NEEDLE DPX5 (#14)	
2	S37819021	1	ニードルDPX5(#14)	NEEDLE DPX5 (#14)	
1	S37813021	1	ニードルDPX5(#14)	NEEDLE DPX5 (#14)	
1-1	S37813021	1	ニードルDPX5(#14)	NEEDLE DPX5 (#14)	
1-2	S37813021	1	ニードルDPX5(#14)	NEEDLE DPX5 (#14)	
1-3	S37813021	1	ニードルDPX5(#14)	NEEDLE DPX5 (#14)	

From the library of: Diamond Needle Corp

B. 針棒・天秤関係 / Needle bar and thread take-up mechanism

/ Nadelstange und Fadenabnahmevorrichtung

/ Mécanisme de la barre à aiguille et releveur de fil

/ Mecanismo de la barra de aguja y tirahilos

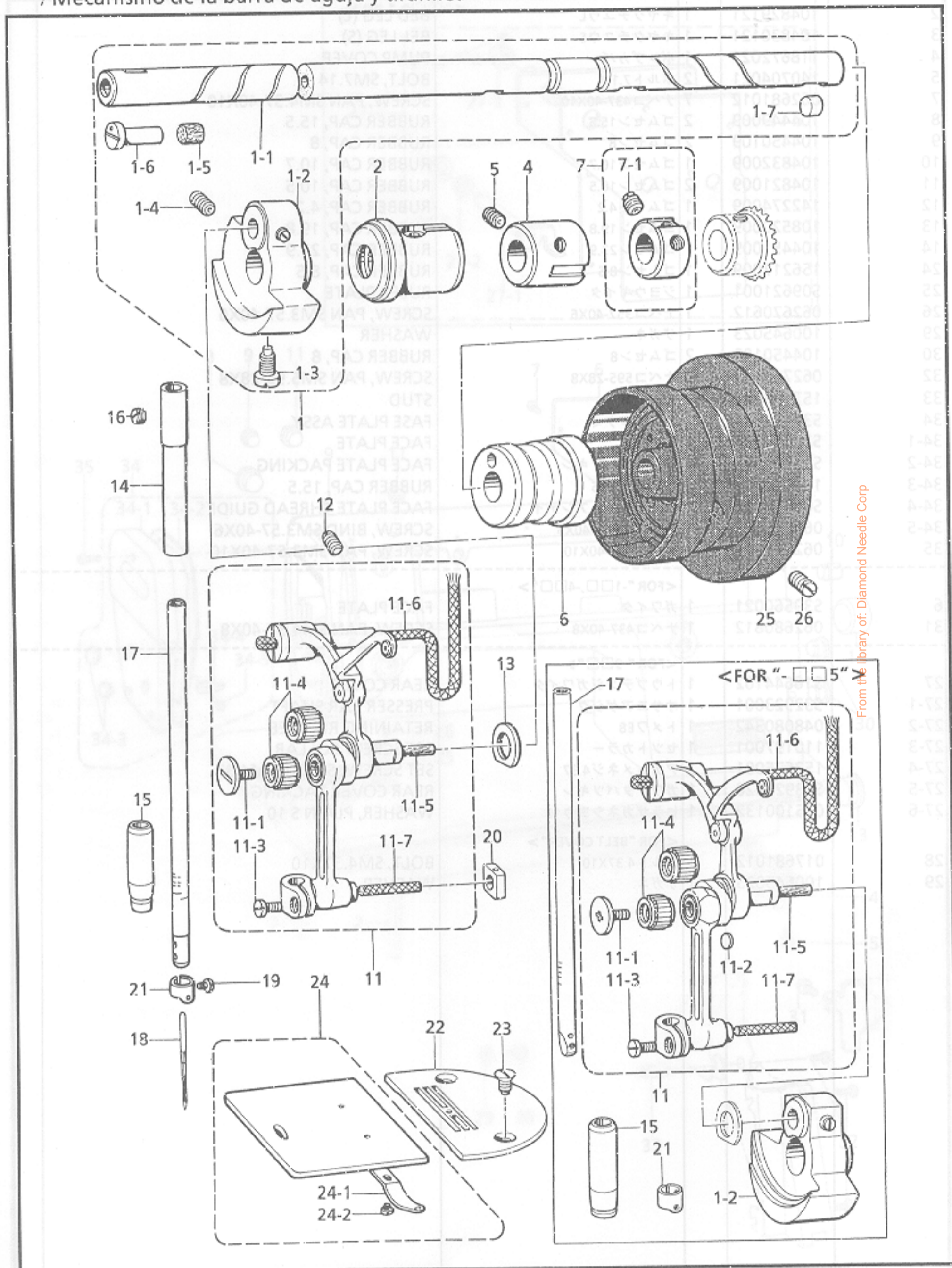

From the library of: Diamond Needle Corp

B. 針棒・天秤関係 / Needle bar and thread take-up mechanism
 / Nadelstange und Fadenabnahmevorrichtung
 / Mécanisme de la barre à aiguille et releveur de fil
 / Mecanismo de la barra de aguja y tirahilos

REF.NO.	CODE	Q'TY	ヒンメイ	NAME OF PARTS	RM
2	S37815021	1	ウワジクメタルL	UPPER SHAFT BUSH (L)	
4	140726020	1	ウワジクメタルM	UPPER SHAFT BUSH (M)	
5	013760610	1	トメネジ5.95クボミ	SET SCREW, (CP) SM5.95	
6	S02524001	1	ウワジクメタルR	UPPER SHAFT BUSH (R)	
7	181916121	1	セツトカラークミ	SET SCREW COLLAR ASSY	
7-1	100251001	2	トメネジ6.35	SET SCREW, SM6.35	
12	013781012	1	トメネジ6.35クボミ	SET SCREW, (CP) SM6.35	
13	110367001	1	ザガネ	WASHER, PLAIN SPECIAL 8	
14	117242021	1	ハリボウメタルU	NEEDLE BAR BUSH (U)	
16	100260001	1	トメネジ5.95	SET SCREW, SM5.95	
19	140553102	1	アタマツキトメネジ3.18	SET SCREW, SM3.18	
20	102630021	1	ハリボウアンナイカクコマ	NEEDLE BAR GUIDE SLIDE BLOCK	
23	100032004	2	サラネジ4.37	SCREW, FLAT SM4.37	
24	180018121	1	スベリイタクミ	SLIDE PLATE ASSY	
24-1	114561021	1	スベリイタウラバネ	SPRING	
24-2	122771002	2	シメネジ2.38	SCREW, SM2.38	
25	S02538029	1	プーリ	PULLEY	
26	S33689002	2	アタマトメクボミ 595-14	SET SCREW, (CP) SM5.95-14	
<FOR "□□1, □□3">					
1	S37812021	1	ウワジククミ	UPPER SHAFT ASSY	
1-1	S37814021	1	ウワジク	UPPER SHAFT	
1-2	S06325021	1	テンピンクランククミ	THREAD TAKE-UP CRANK ASSY	
1-3	104464001	1	シメネジ7.14	SCREW, SM7.14	
1-4	014771022	1	アナトメネジ6.35クボミ	SET SCREW, SOCKET (CP) SM6.35	
1-5	146327001	1	フェルト7X10	FELT 7X10	
1-6	146333001	1	オイルチヨウセツベン	OIL REGULATE VALVE	
1-7	156641001	1	ゴムセン7.4	RUBBER CAP, 7.4	
11	S34295001	1	ハリボウレンカククミ	NEEDLE TAKE-UP LEVER ASSY	
11-1	145465001	1	シメネジ3.57L	SCREW, SM3.57L	
11-3	140004001	1	シメネジ3.57	SCREW, SM3.57	
11-4	147777000	2	ニードルベアリング	NEEDLE BEARING	
11-5	145624000	1	フェルト	FELT	
11-6	155488000	1	クミヒモ	WICK (L = 90)	
11-7	158727001	1	クミヒモ4X4	WICK 4X4 (L = 27)	
15	S35817021	1	ハリボウメタルD	NEEDLE BAR BUSH (D)	
21	S14814001	1	ハリボウイトアンナイ	NEEDLE BAR THREAD GUIDE	
22	S03884321	1	ハリイタE16	NEEDLE PLATE (E16)	
22	111859321	1	ハリイタE18	NEEDLE PLATE (E18)	
<FOR "□□1, □□3">					
17	S14811021	1	ハリボウDB	NEEDLE BAR (DB)	
17	S14815021	1	ハリボウDP	NEEDLE BAR (DP)	
18	100265031	1	ミシンハリDBX1	NEEDLE DBX1 (#11)	
18	107415011	1	ミシンハリDPX5	NEEDLE DPX5 (#11)	
18	100265034	1	ミシンハリDBX1	NEEDLE DBX1 (#14)	
18	107415014	1	ミシンハリDPX5	NEEDLE DPX5 (#14)	
<FOR "□□5">					
1	S37813021	1	ウワジククミ	UPPER SHAFT ASSY	
1-2	S00909021	1	テンピンクランククミ	THREAD TAKE-UP CRANK ASSY	
11	S34290021	1	ハリボウレンカククミ	NEEDLE TAKE-UP LEVER ASSY	
11-1	S13163001	1	シメネジ3.5L	SCREW, M3.5L	
11-2	145600020	1	フタ	CAP	
11-3	140004001	1	シメネジ3.57	SCREW, SM3.57	

From the library of: Diamond Needle Corp

B. 針棒・天秤関係 / Needle bar and thread take-up mechanism
 / Nadelstange und Fadenabnahmevorrichtung
 / Mécanisme de la barre à aiguille et releveur de fil
 / Mecanismo de la barra de aguja y tirahilos

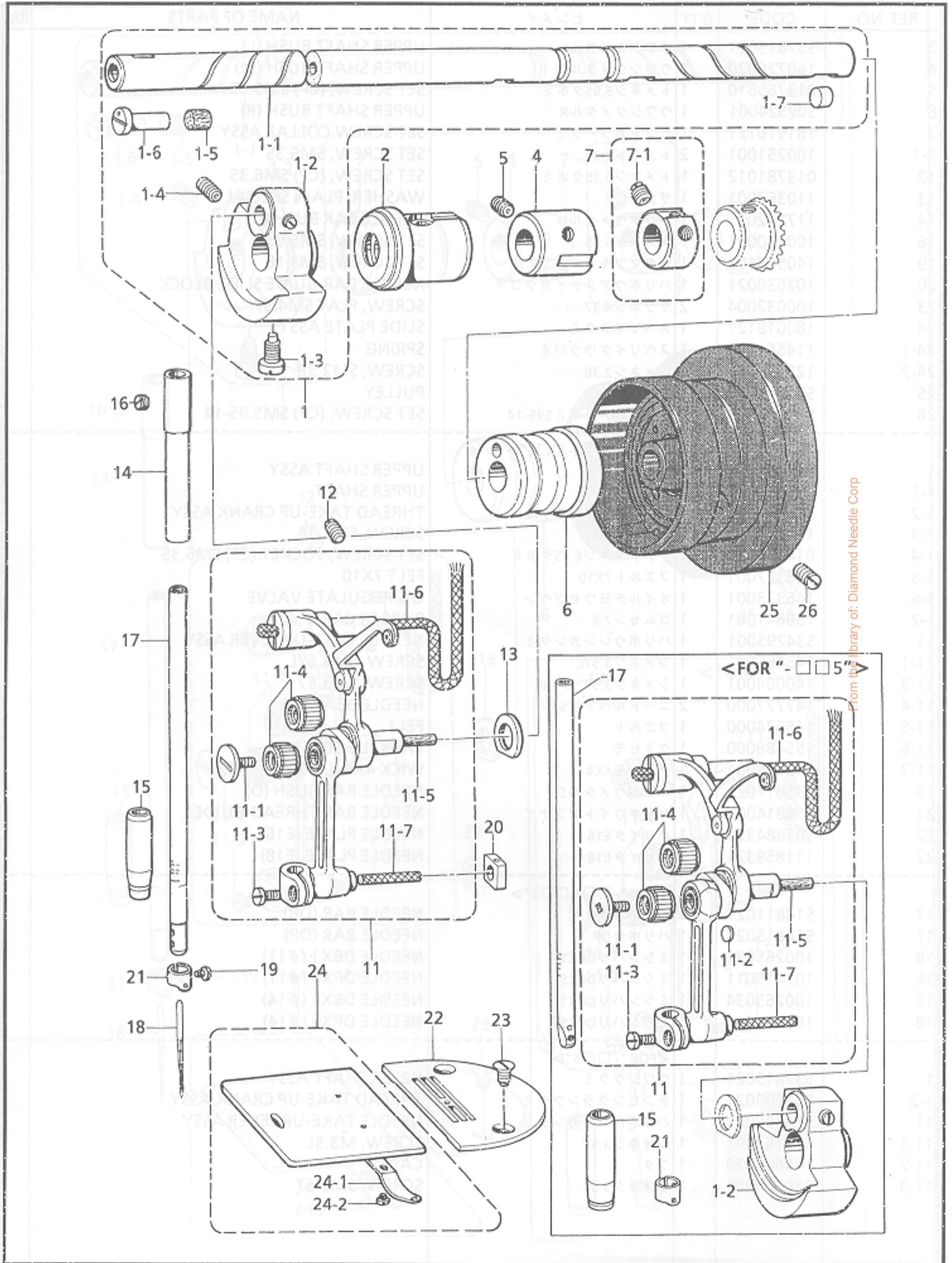

B. 針棒・天秤関係 / Needle bar and thread take-up mechanism
 / Nadelstange und Fadenabnahmevorrichtung
 / Mécanisme de la barre à aiguille et releveur de fil
 / Mecanismo de la barra de aguja y tirahilos

REF.NO.	CODE	Q'TY	ヒンメイ	NAME OF PARTS	RM
11-4	147777000	2	<FOR "□□5"> ニードルベアリング	PRESSER ADJUST SCREW NEEDLE BEARING	
11-5	145624000	1	フェルト	FELT	
11-6	155488000	1	クミヒモ	WICK (L = 90)	
11-7	158727001	1	クミヒモ4X4	WICK 4X4 (L = 27)	
15	147326021	1	ハリボウメタルD	NEEDLE BAR BUSH (D)	
17	S02811001	1	ハリボウ	NEEDLE BAR	
18	100265042	1	ミシンハリDBX1	NEEDLE DBX1 (#22)	
21	151594001	1	ハリボウイトアンナイ	NEEDLE BAR THREAD GUIDE	
22	111508001	1	ハリイタC26	NEEDLE PLATE (C26)	
22	150792021	1	ハリイタH26	NEEDLE PLATE (H26)	

18	100265036	1	" OPTION PARTS " ミシンハリDBX1	NEEDLE DBX1 (#16)	
18	100265039	1	ミシンハリDBX1	NEEDLE DBX1 (#19)	
18	107415022	1	ミシンハリDPX5	NEEDLE DPX5 (#22)	
26	062351216		ナベコ35X2	WASHER, PLAIN	
27	102707021		ザガネ	WASHER, PLAIN	
28	S1952021		オサエアゲクランク	PRESSER BAR LIFTER CRANK	
29	150384121		フィンガーガード	FINGER GUARD	
30	S28919021		ヒラザガネシヨウ	WASHER, PLAIN	
31	S31013001		ナベコ35X2	WASHER, PLAIN	
35	S00879021		オサエボウヂキ	PRESSER BAR GUIDE BRACKET	
36	142403001		ボルトS35	BOLT, S35	
5	147514001		<FOR "□□1"> オサエバネ	PRESSER SPRING	
5	141728001		<FOR "□□3-□□5"> オサエバネ	PRESSER SPRING	
5	S13561101		<FOR "□□1"> オサエバネ	PRESSER SPRING	
7	S3690201		<FOR "□□1-□□3"> オサエクミ	PRESSER FOOT ASSY	
7	S3690501		<FOR "□□3"> オサエクミ	PRESSER FOOT ASSY	
7	S3690301		<FOR "□□5"> オサエクミ	PRESSER FOOT ASSY	
7	S3690401		オサエクミ	PRESSER FOOT ASSY	
7	113280121		" OPTION PARTS " <FOR "□□1, □□3"> オサエクミ	PRESSER FOOT ASSY <Finger guard less>	
7	153037201		オサエクミ	PRESSER FOOT ASSY <Finger guard less>	
7	145157101		<FOR "□□5"> オサエクミ	PRESSER FOOT ASSY <Finger guard less>	
7	150789101		オサエクミ	PRESSER FOOT ASSY <Finger guard less>	
7-1	S363000201		フィンガーガード	FINGER GUARD	

From the library of: Diamond Needle Corp

C. 押工関係 / Presser foot mechanism / Stoffdrückerfuß / Mécanisme de pied presseur
 / Mecanismo de la prensa tela

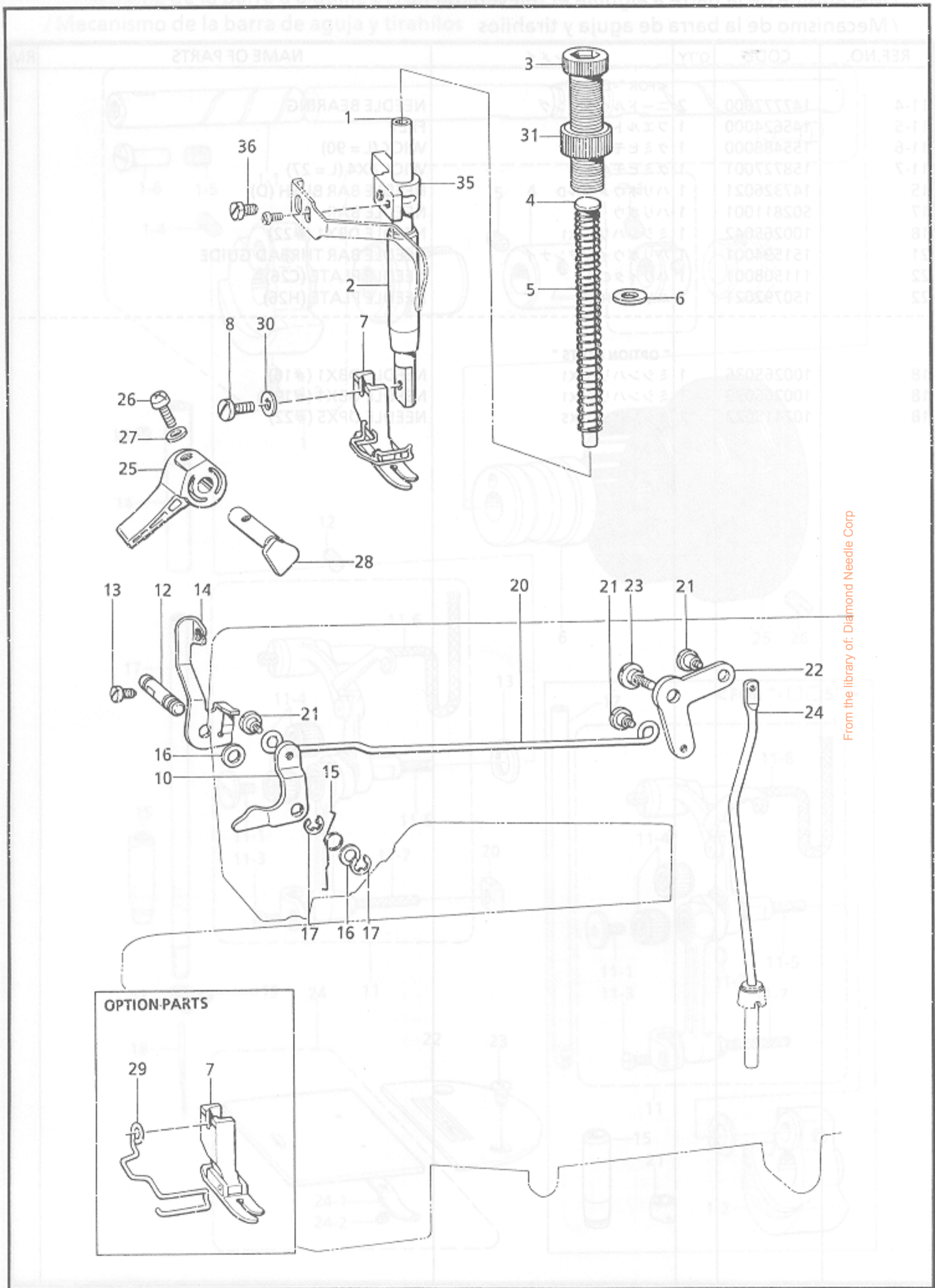

From the library of: Diamond Needle Corp

C. 押工関係 / Presser foot mechanism / Stoffdrückerfuß / Mécanisme de pied presseur
/ Mecanismo de la prensa tela

REF.NO.	CODE	Q'TY	ヒンメイ	NAME OF PARTS	RM
1	111466121	1	オサエボウ	PRESSER BAR	
2	145472021	1	オサエボウメタル	PRESSER BAR BUSH	
3	S31012001	1	オサエチヨウセツネジ	PRESSER ADJUST SCREW	
4	141208021	1	オサエバネアンナイ	SPRING GUIDE	
6	140407001	1	ザガネ	WASHER	
8	S13385001	1	シメネジ3.57X10	SCREW, SM3.57X10	
10	145580021	1	オサエアゲレバー	PRESSER BAR LIFTER LEVER	
12	145474101	1	オサエアゲレバーシャフト	PRESSER BAR LIFTER LEVER SHAFT	
13	S01998021	1	アタマツキトメネジ3.57	SET SCREW, SM3.57	
14	S02546202	1	イトユルメイタ	TENSION RELEASE PLATE	
15	145475101	1	オサエアゲレバーバネ	SPRING	
16	109763022	1	ザガネ	WASHER	
17	048040342	2	トメワE4	RETAINING RING, E4	
20	145476021	1	ヒザアゲレンカン	KNEE LIFTER CONNECTING ROD	
21	145478022	3	ダンネジ4.76	SHOULDER SCREW, SM4.76	
22	145479022	1	ヒザアゲレバー	KNEE LIFTER LEVER	
23	145480101	1	ダンネジ6.35	SHOULDER SCREW, SM6.35	
24	S02548001	1	ヒザアゲボウ	KNEE LIFTER BAR	
25	S31006001	1	オサエアゲテコ	PRESSER BAR LIFTER	
26	062351216	1	ナベコ35X12	SCREW, PAN M3.5X12	
27	102707021	1	ザガネ	WASHER	
28	S31952021	1	オサエアゲクランク	PRESSER BAR LIFTER CRANK	
29	150384121	1	フィンガーガード	FINGER GUARD	
30	S28919021	1	ヒラザガネシヨウ	WASHER, PLAIN S	
31	S31013001	1	チヨウセツネジツマミナツト	PRESSER ADJUST NUT	
35	S00879021	1	オサエボウダキ	PRESSER BAR GUIDE BRACKET	
36	142403001	1	ボルト5.95	BOLT, SM5.95	
5	147514001	1	オサエバネ <FOR "-□□1">	PRESSER SPRING	
5	141728001	1	オサエバネ <FOR "-□□3,-□□5">	PRESSER SPRING	
5	S13561101	1	オサエバネ <FOR "-□□3">	PRESSER SPRING	
7	S36902021	1	オサエクミ <FOR "-□□1,-□□3">	PRESSER FOOT ASSY	
7	S36905001	1	オサエクミ <FOR "-□□3">	PRESSER FOOT ASSY	
7	S36903001	1	オサエクミ <FOR "-□□5">	PRESSER FOOT ASSY	
7	S36904021	1	オサエクミ	PRESSER FOOT ASSY	
7	113280121	1	オサエクミ " OPTION PARTS " <FOR "-□□1,-□□3">	PRESSER FOOT ASSY <Finger guard -less>	
7	153037201	1	オサエクミ	PRESSER FOOT ASSY <Finger guard -less>	
7	145157101	1	オサエクミ <FOR "-□□5">	PRESSER FOOT ASSY <Finger guard -less>	
7	150789101	1	オサエクミ	PRESSER FOOT ASSY <Finger guard -less>	
7-1	S36900020	1	フィンガーガード	FINGER GUARD	

From the library of: Diamond Needle Corp

D. 送り関係 / Feed mechanism / Transportvorrichtung / Mécanisme de l'entraînement / Mecanismo de la alimentación

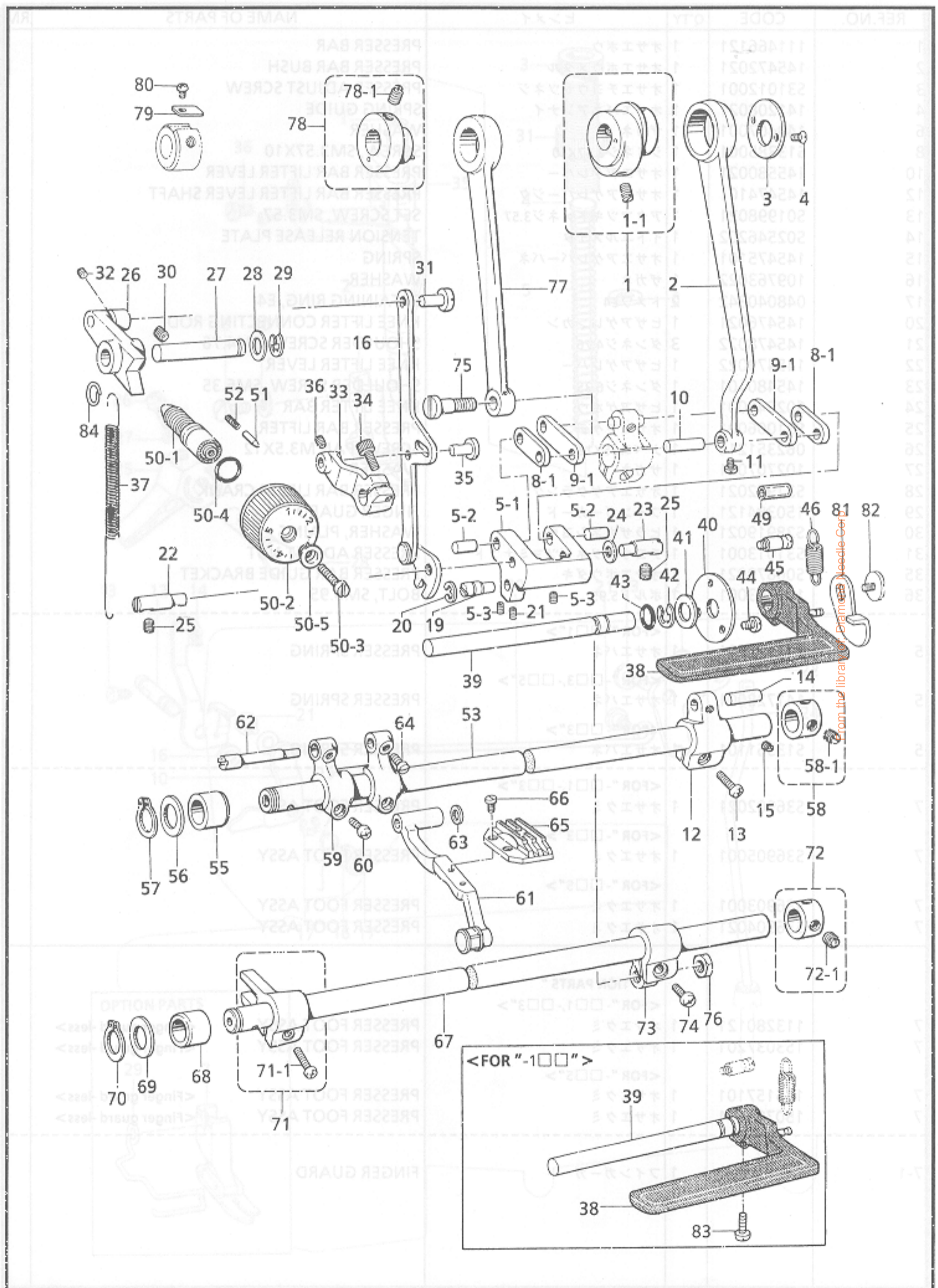

D. 送り関係 / Feed mechanism / Transportvorrichtung / Mécanisme de l'entraînement / Mecanismo de la alimentación

REF.NO.	CODE	Q'TY	ヒンメイ	NAME OF PARTS	RM
2	S02554001	1	スイハイオクリレンカン	LEVEL FEED CONNECTING ROD	
3	156948021	1	レンカンオサエ	CONNECTING ROD PRESSER	
4	108960002	2	サラネジ3.57	SCREW, FLAT SM3.57	
5	S05898021	1	キリカエキクミ	LEVEL REGULATOR ASSY	
5-1	156950120	1	キリカエキ	LEVEL REGULATOR	
5-2	156951021	2	オクリリンクジク	FEED LINK STUD	
5-3	014680622	2	アナトメネジ4.37クボミ	SET SCREW, SOCKET (CP) SM4.37	
8	156952021	1	スイハイオクリリンククミ	FEED ROCK LINK ASSY	
8-1	156953021	2	スイハイオクリリンク	FEED ROCK LINK	
9	156954021	1	スイハイオクリウデリンククミ	FEED ROCK ARM LINK ASSY	
9-1	156955021	2	スイハイオクリウデリンク	FEED ROCK ARM LINK	
10	156956021	1	リンクジク	LINK SHAFT	
11	144458001	1	アタマツキトメネジ3.57	SET SCREW, SM3.57	
12	156957020	1	スイハイオクリウデ	FEED ROCK ARM	
13	062711412	1	ナベコ4.76-32X14	SCREW, PAN SM4.76-32X14	
14	156958021	1	スイハイオクリウデジク	FEED ROCK ARM STUD	
15	014680622	1	アナトメネジ4.37クボミ	SET SCREW, SOCKET (CP) SM4.37	
16	158021122	1	キリカエキレンカンクミ	FEED REGULATOR CONNECTING ROD ASSY	
19	156966121	1	ヘンシンピン	PIN	
20	048060342	1	トメワE6	RETAINING RING, E6	
21	014680622	1	アナトメネジ4.37クボミ	SET SCREW, SOCKET (CP) SM4.37	
22	156967021	1	キリカエジクL	FEED REGULATOR SHAFT (L)	
23	118734021	1	キリカエキジク	FEED REGULATOR SHAFT	
24	118735021	1	ザガネ	WASHER	
25	151604001	2	トメネジ5.95	SET SCREW, SM5.95	
26	156969021	1	オクリチヨウセツキ	FEED REGULATOR	
27	156970021	1	オクリチヨウセツキジク	FEED REGULATOR SHAFT	
28	S02556001	1	ザガネ	WASHER	
29	048070342	1	トメワE7	RETAINING RING, E7	
30	014761030	1	アナクボミ595-28X10	SET SCREW, SOCKET (CP) SM5.95	
31	151308121	1	レンカンジク12.5	CONNECTING STUD 12.5	
32	014680422	1	アナトメネジ4.37クボミ	SET SCREW, SOCKET (CP) SM4.37	
33	S02557000	1	レバー	FEED REGURATOR BRACKET	
34	S07959001	1	アナホルト476-32X14	BOLT, SOCKET SM4.76-32X14	
35	151308121	1	レンカンジク12.5	CONNECTING STUD 12.5	
36	014680422	1	アナトメネジ4.37クボミ	SET SCREW, SOCKET (CP) SM4.37	
38	S32920001	1	カエシヌイレバークミ	REVERSE LEVER ASSY	
40	147504021	1	カンザ	WASHER	
41	S35818021	1	ヒラザガネシヨウ10	WASHER, PLAIN S10	
42	048080342	1	トメワE8	RETAINING RING, E8	
43	104564001	1	Oリング	O RING	
44	062670712	3	ナベコ357-40X7	SCREW, PAN SM3.57-40X7	
1	S02552021	1	<FOR "-□□1,-□□3"> スイハイヘンシンリンネジツキ	LEVEL FEED ECCENTRIC WHEEL	
37	S02558201	1	ヒキバネ	SPRING	
1	156946021	1	<FOR "-□□5"> スイハイヘンシンリンネジツキ	LEVEL FEED ECCENTRIC WHEEL	
37	S03818101	1	ヒキバネH	SPRING (H)	
1-1	013761410	2	トメネジ5.95クボミ	SET SCREW, (CP) SM5.95	
39	S32922021	1	<FOR "-1□□"> カエシヌイレバークミ	REVERSE STITCHING LEVER SHAFT	
39	149085001	1	<FOR "-4□□,-9□□"> カエシヌイレバークミ	REVERSE STITCHING LEVER SHAFT	

From the library of: Diamond Needle Corp

D. 送り関係 / Feed mechanism / Transportvorrichtung / Mécanisme de l'entraînement
 / Mecanismo de la alimentación

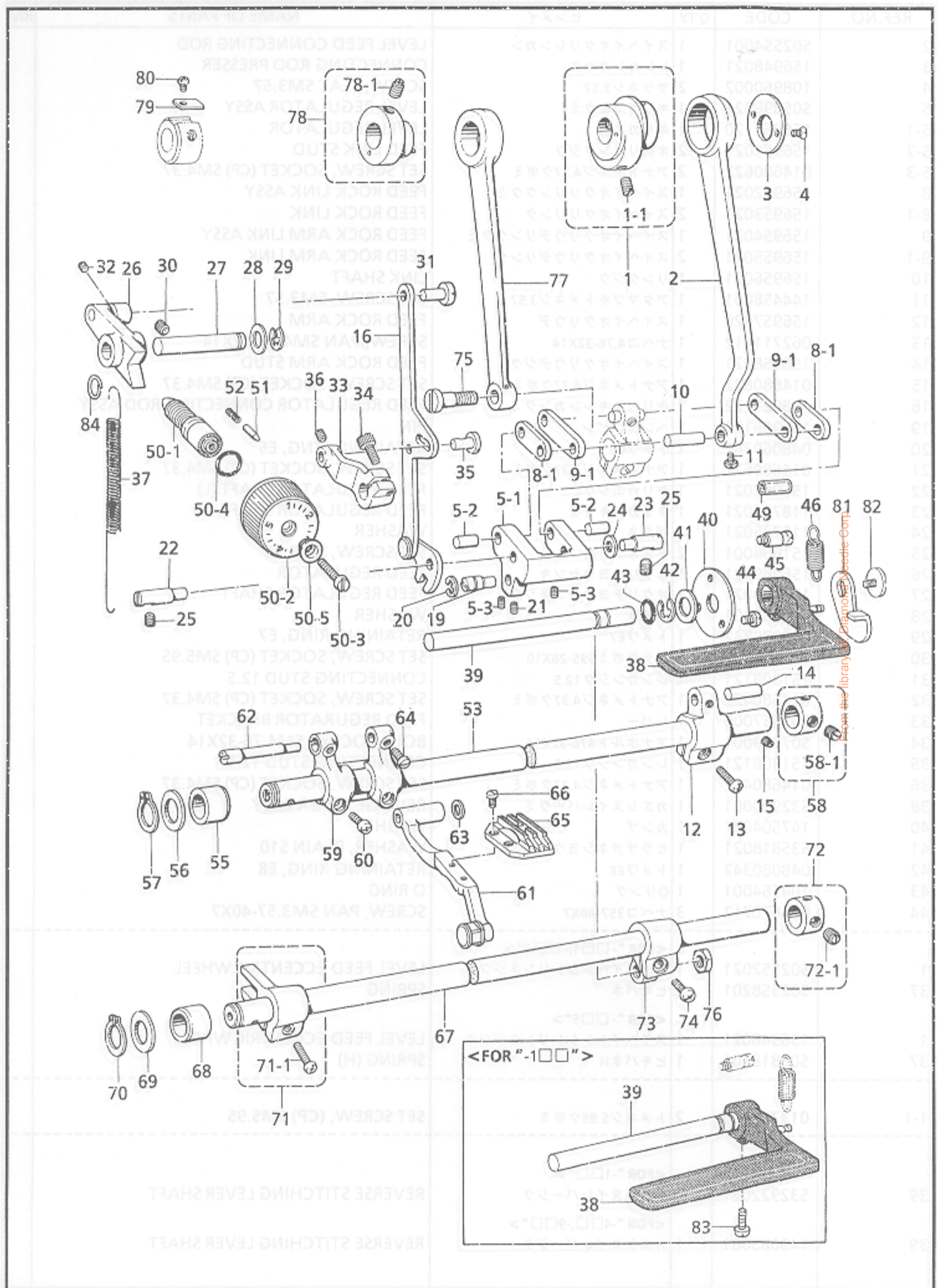

From the library of Diamol Needle Corp.

D. 送り関係 / Feed mechanism / Transportvorrichtung / Mécanisme de l'entraînement
 / Mecanismo de la alimentación

REF.NO.	CODE	Q'TY	ヒンメイ	NAME OF PARTS	RM
45	S02562001	1	バネカケ	SPRING HOOK	
46	S02563001	1	モドシバネ	SPRING	
49	153132000	1	ナイロンチューブ	NYLON TUBE	
50	S31018021	1	<FOR Stitch length "5"> オクリメモリダイヤルクミ	STITCH LENGTH DIAL ASSY	
50-2	S31019001	1	オクリメモリダイヤル	STITCH LENGTH DIAL	
50	S31015021	1	<FOR Stitch length "4"> オクリメモリダイヤルクミ	STITCH LENGTH DIAL ASSY	
50-2	S31016001	1	オクリメモリダイヤル	STITCH LENGTH DIAL	
50-1	S06999021	1	オクリチヨウセツネジ	ADJUST SCREW	
50-3	S21514121	1	シメネジ4.76	SCREW, SM4.76	
50-4	108549001	1	Oリング	O RING	
50-5	142746022	1	メモリイタオサエ	PLATE SUPPORT	
51	145502021	1	メモリイチギメピン	POSITIONING PIN	
52	100328001	1	メモリイチキメピンバネ	SPRING	
53	S02568121	1	スイハイオクリジク	FEED ROCK SHAFT	
55	S31014020	1	メタル19.3	BUSH 19.3	
56	156243021	1	オクリジクスラストリング	THRUST RING	
57	048150142	1	トメワジクヨウC15	RETAINING RING, C15	
58	183493021	1	オクリジクセットカラークミ	FEED SHAFT SET COLLAR ASSY	
58-1	101706001	2	トメネジ6.35	SET SCREW, SM6.35	
59	156244020	1	スイハイオクリダイウデ	FEED ROCK BRACKET ARM	
60	062681212	2	ナベコ437-40X12	SCREW, PAN SM4.37-40X12	
61	S02569121	1	オクリダイクミ	FEED BRACKET ASSY	
62	S25349021	1	オクリダイジク	FEED BRACKET SHAFT	
63	158722021	1	ザガネ4.2	WASHER 4.2	
64	120990001	2	アタマツキトメネジ4.37	SET SCREW, SM4.37	
65	S03885001	1	<FOR"-□□1"> オクリバ	FEED DOG	
65	111860101	1	<FOR"-□□3"> オクリバ	FEED DOG	
65	S02742001	1	<FOR"-□□3,-□□5"> オクリバ	FEED DOG	
65	150793001	1	<FOR"-□□5"> オクリバ	FEED DOG	
66	100080003	2	シメネジ3.18	SCREW, SM3.18	

From the library of: Diamond Needle Corp

D. 送り関係 / Feed mechanism / Transportvorrichtung / Mécanisme de l'entraînement
 / Mecanismo de la alimentación

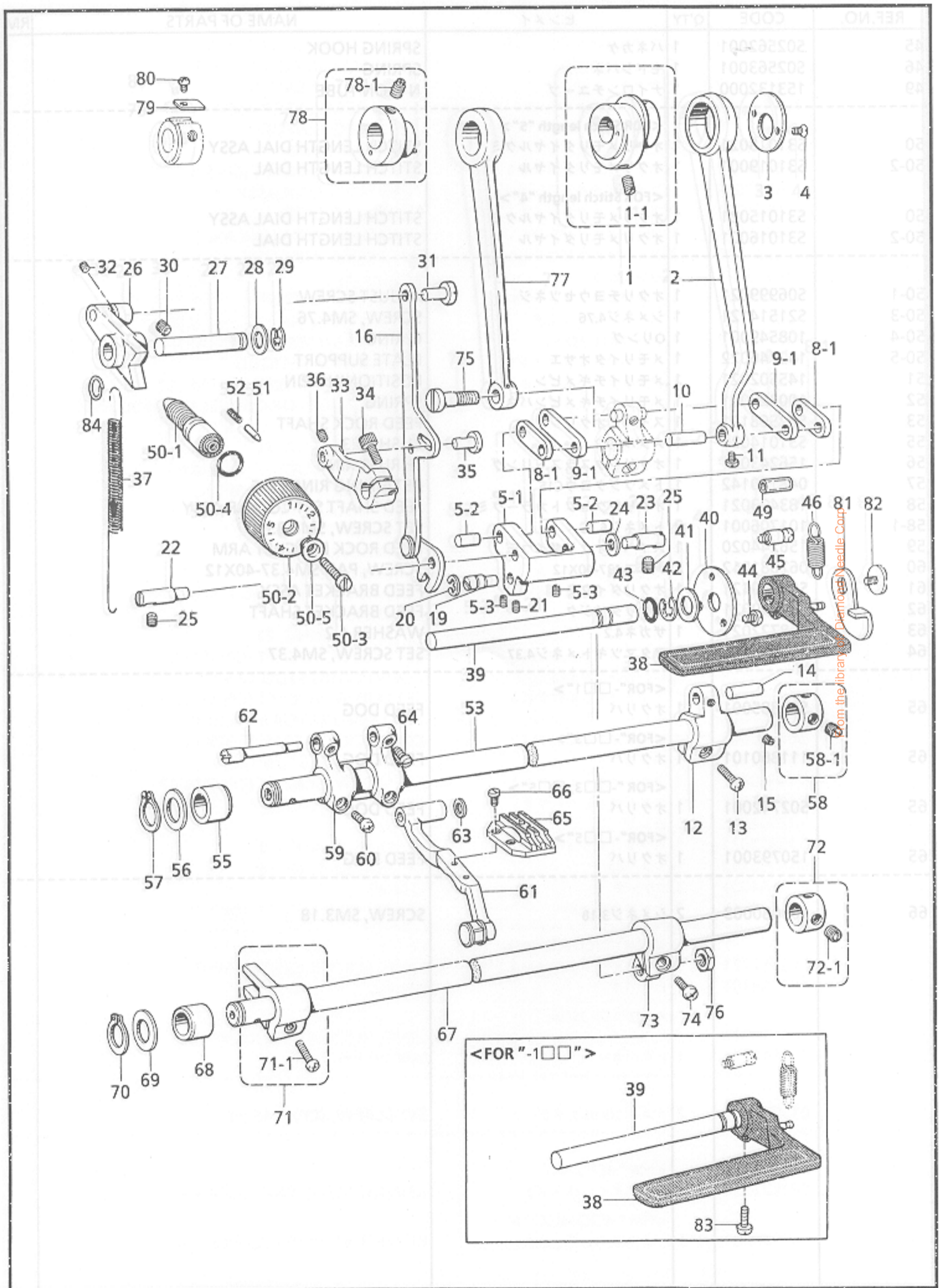

D. 送り関係 / Feed mechanism / Transportvorrichtung / Mécanisme de l'entraînement / Mecanismo de la alimentación

REF.NO.	CODE	Q'TY	ヒンメイ	NAME OF PARTS	RM
67	S02574121	1	ジヨウゲオクリジク	FEED LIFTING ROCK SHAFT	
68	S31014020	1	メタル19.3	BUSH 19.3	
69	156243021	1	オクリジクスラストリング	THRUST RING	
70	048150142	1	トメワジクヨウC15	RETAINING RING, C15	
71	180322021	1	ジヨウゲオクリウデクミ	FEED LIFTING ROCK SHAFT CRANK	
71-1	062681412	1	ナベコ437-40X14	SCREW, PAN SM4.37-40X14	
72	183493021	1	オクリジクセットカラークミ	FEED SHAFT SET COLLAR ASSY	
72-1	101706001	2	トメネジ6.35	SET SCREW, SM6.35	
73	S02575000	1	ジヨウゲオクリジクウデ	FEED LIFTING ROCK SHAFT CRANK	
74	062711212	1	ナベコ476-32X12	SCREW, PAN SM4.76-32X12	
75	147509021	1	ダンネジ7.14	SHOULDER SCREW, SM7.14	
76	104689002	1	ナツト7.14	NUT, SM7.14	
77	118758021	1	ジヨウゲオクリレンカン	FEED LIFTING CONNECTING ROD	
79	159690021	1	オクリカムストツパー	FEED CAM STOPPER	
78	S02576021	1	<FOR "-□□1,-□□3"> ヘンシンリンネジツキ	ECCENTRIC WHEEL WITH SCREW	
78	159708021	1	<FOR "-4□3,-9□3"> ヘンシンリンネジツキ	ECCENTRIC WHEEL WITH SCREW	
78	159706021	1	<FOR "-□□5"> ヘンシンリンネジツキ	ECCENTRIC WHEEL WITH SCREW	
78-1	151604001	2	トメネジ5.95	SET SCREW, SM5.95	
80	062670412	1	ナベコ357-40X4	SCREW, PAN SM3.57-40X4	
82	100511003	1	シメネジ4.76	SCREW, SM4.76	
84	S04228001	1	バネカケ	SPRING HOOK	
85	213765021	1	ナミワ02X10.5X20	WAVE RING, 02X10.5X20	
86	153484021	1	ザガネ4.76	WASHER, PLAIN 4.76	
87	S35830021	1	バネザガネ2-5	WASHER, SPRING 2-5	
81	S02578101	1	<FOR "-4□□,-9□□"> カエシヌイレバーイタ	REVERSE STITCHING LEVER PLATE	
83	S37333001	1	ナベコ4.76-32X14	SCREW, PAN SM4.76-32X14	
1-1-1	062780812	1	ナベコ635-28X8	SCREW, PAN SM6.35-28X8	
1-1-2	018761822	1	アナボルト5.95X18	BOLT, SOCKET 5.95X18	
1-1-3	048050142	1	トメワジクヨウC5	RETAINING RING, C5	
1-1-4	062671012	1	ナベコ357-40X10	SCREW, PAN SM3.57-40X10	
1-1-5	002300603	1	シメネジ3X6	SCREW, PAN SM3X6	
1-1-6	062681412	1	ナベコ437-40X6	SCREW, PAN SM4.37-40X6	
1-1-7	062670612	1	ナベコ357-40X6	SCREW, PAN SM3.57-40X6	
1-2	S02592009	1	シンシタイカバー	TERMINAL BLOCK COVER	
1-3	062670612	1	ナベコ357-40X6	SCREW, PAN SM3.57-40X6	
2	S32924001	1	カエシヌイレバーウデ	REVERSE BAR LFT/RR ARM	
3	062711212	1	ナベコ476-32X12	SCREW, PAN SM4.76-32X12	
4	S16641004	1	スタッド	STUD (L)	
5	062781412	1	ナベコ635-28X14	SCREW, PAN SM6.35-28X14	
6	S16642001	1	スタッドRS	STUD (R)	
7	062781012	1	ナベコ635-28X10	SCREW, PAN SM6.35-28X10	
8	S16643001	1	カバー	COVER	
9	002670812	1	ナベコ3.57-40X8	SCREW, PAN SM3.57-40X8	

From the library of: Diamond Needle Corp

E. 膝上げ関係 (-1□□,-4□□) / Knee lifter mechanism (-1□□,-4□□)
 / Kniehebel (-1□□,-4□□ / Mécanisme de genouillère (-1□□,-4□□)
 / Mecanismo de levantador de rodilla (-1□□,-4□□)

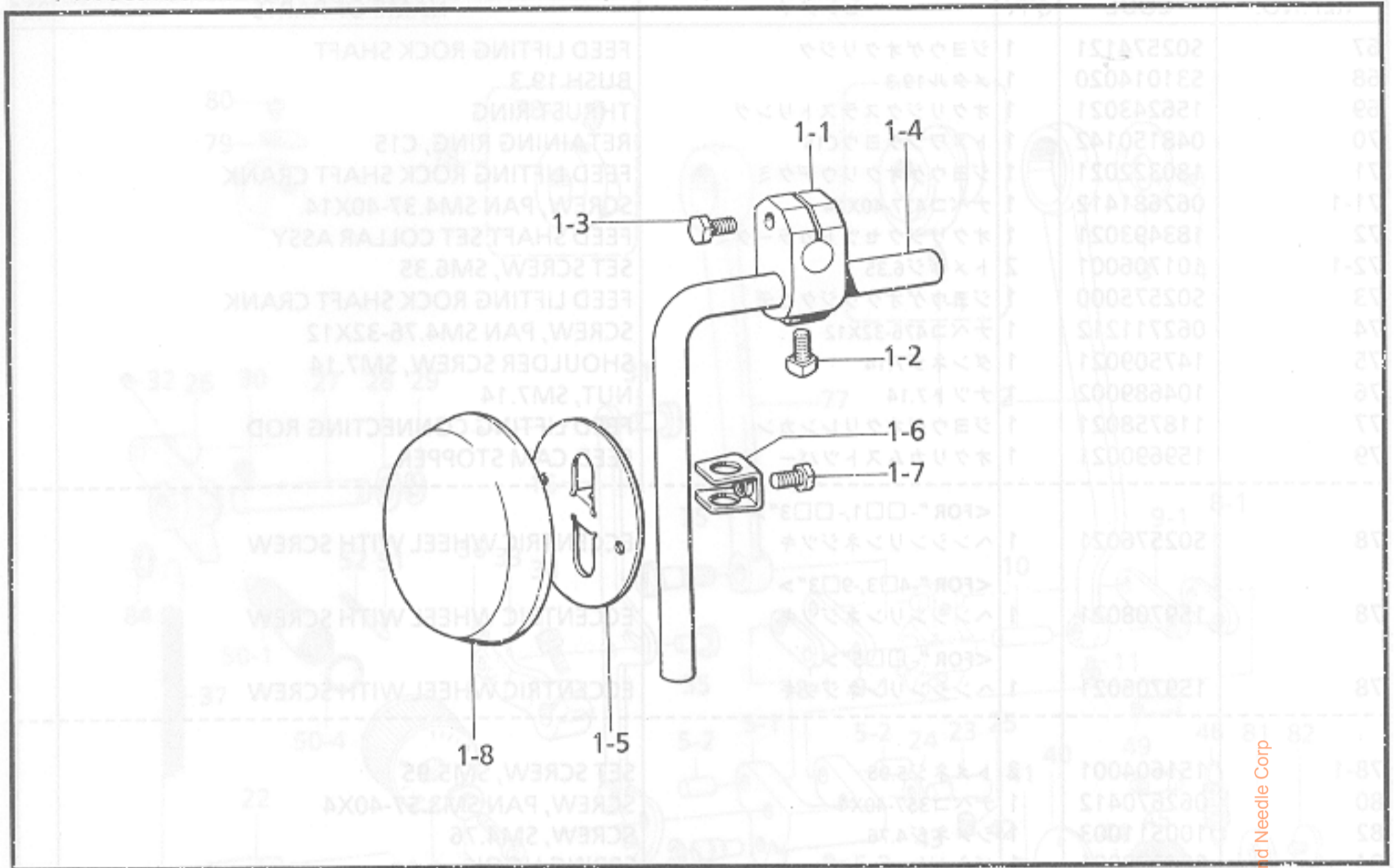

877-201-203

F. 押エ上げ関係 (-9□□) / Presser foot lifter mechanism (-9□□)
 / Stoffhalterhebevorrchtung (-9□□) / Mécanisme de leveur du pinceur (-9□□)
 / Mecanismo del levantador de ménsula de trabajo (-9□□)

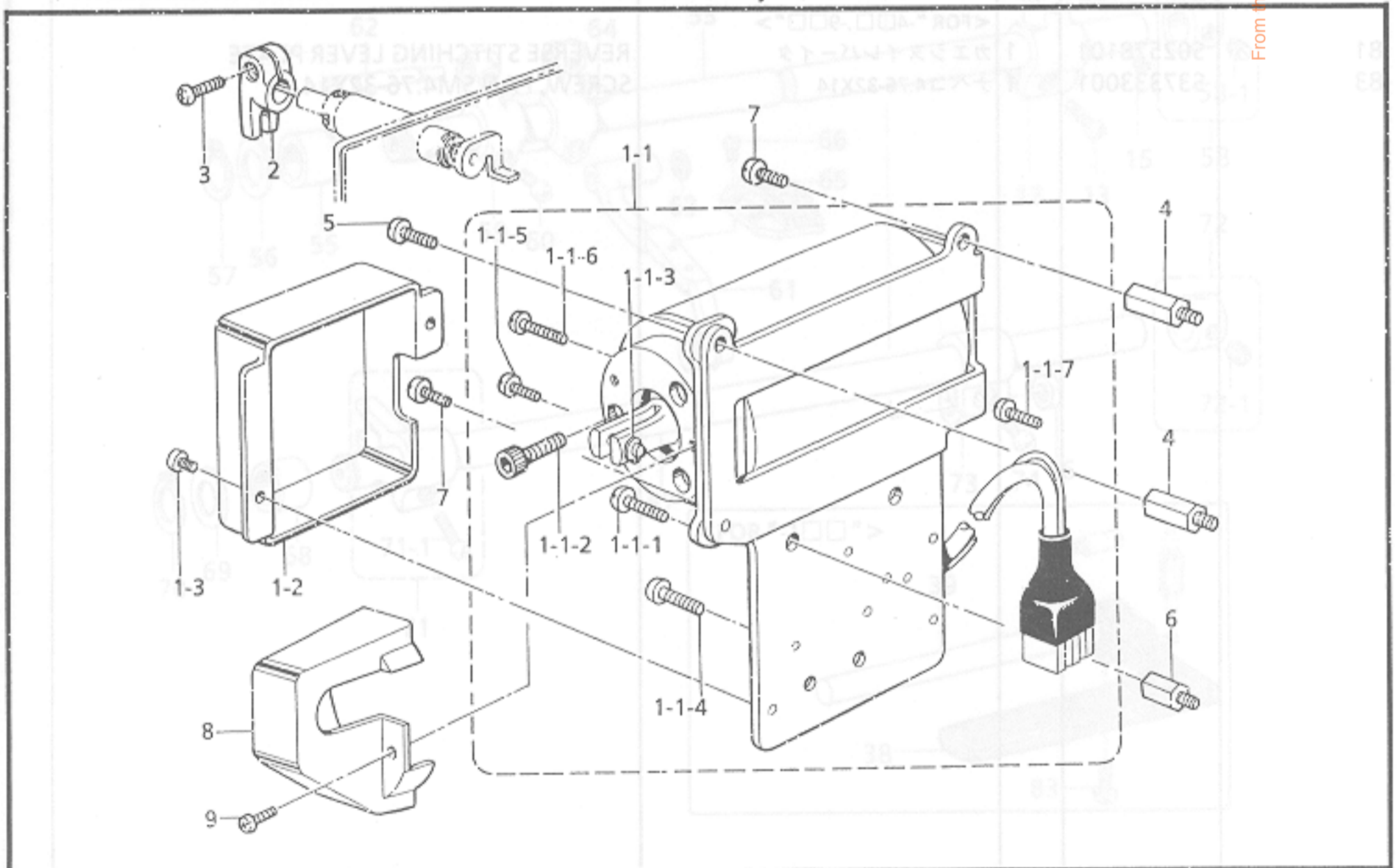

877-201-204

E. 膝上げ関係 (-1□□,-4□□) / Knee lifter mechanism (-1□□,-4□□)
 / Kniehebel (-1□□,-4□□) / Mécanisme de genouillère (-1□□,-4□□)
 / Mecanismo de levantador de rodilla (-1□,-4□)

REF.NO.	CODE	Q'TY	ヒンメイ	NAME OF PARTS	RM
1	S35821021	1	ヒザアテクミ	KNEE LIFTER ASSY	
1-1	146039021	1	ヒザアテツギテ	KNEE LIFTER JOINT	
1-2	100463021	1	4カクボルト7.94	BOLT, SM7.94	
1-3	S35820021	1	ボルト5.95X20	BOLT, SM5.95X20	
1-4	104619022	1	ヒザアゲタテジク	KNEE LIFTER BAR	
1-5	S34756021	1	ヒザアテ	KNEE LIFTER PLATE	
1-6	114967021	1	ヒザアテストツバ	KNEE LIFTER PLATE STOPPER	
1-7	110087021	1	ボルト5.95	BOLT, SM5.95	
1-8	S31885001	1	ヒザアテカバー	KNEE LIFTER PLATE COVER	
	013750610	1	メネジ5.95クボミ	VERTICAL SHAFT BUSH (D)	
	S31826020	1	メネジ5.95クボミ	SET SCREW, (CP) SM5.95	
	0137501410	1	メネジ5.95クボミ	VERTICAL SHAFT BUSH (D)	
	154552001	1	クボミ	SET SCREW, (CP) SM5.95	
	118761021	1	クボミ	LOWER SHAFT	
	014680622	2	クボミ	LOWER SHAFT BUSH (L)	
	104622020	1	クボミ	SET SCREW, SOCKET (CP) SM4.37	
	121007001	1	クボミ	LOWER SHAFT BUSH (R)	
	181995021	1	クボミ	SET SCREW, SM4.37	
	101705001	2	クボミ	SET SCREW COLLAR ASSY	
	062681212	1	クボミ	SET SCREW, SM6.35	
	093245001	1	クボミ	SCREW, PAN SM4.37-40X12	
	183389001	1	クボミ	ORIGIN ASSY	
	183389001	1	クボミ	TENSION SPRING	
	183389001	1	クボミ	DUST SCREW	
	003245001	1	クボミ	SET SCREW	
		1	クボミ	ORIGIN TENSION SPRING	

877-201-203

F. 押エ上げ関係 (-9□□) / Presser foot lifter mechanism (-9□□)
 / Stoffhalterhebervorrichtung (-9□□) / Mécanisme de leveur du pinceur (-9□□)
 / Mecanismo del levantador de ménsula de trabajo (-9□□)

REF.NO.	CODE	Q'TY	ヒンメイ	NAME OF PARTS	RM
1	S40832051	1	デンジオサエアゲクミ	PRESSER FOOT LIFTER SOL. ASSY	
1-1	S40833051	1	デンジオサエアゲクミT	PRESS. FOOT LIFTER SOL. ASSY	
1-1-1	062780812	1	ナベコ635-28X8	SCREW, PAN SM6.35-28X8	
1-1-2	018761822	3	アナボルト5.95X18	BOLT, SOCKET SM5.95X18	
1-1-3	048050142	2	トメワジクヨウC5	RETAINING RING, C5	
1-1-4	062671012	2	ナベコ357-40X10	SCREW, PAN SM3.57-40X10	
1-1-5	002300603	2	+ナベコ3X6	SCREW, PAN M3X6	
1-1-6	062680663	1	ナベコ437-40X6	SCREW, PAN SM4.37-40X6	
1-1-7	062670612	1	ナベコ357-40X6	SCREW, PAN SM3.57-40X6	
1-2	S02592009	1	タンシダイカバー	TERMINAL BLOCK COVER	
1-3	062670612	2	ナベコ357-40X6	SCREW, PAN SM3.57-40X6	
2	S32924001	1	オサエアゲウデ	PRESSER BAR LIFTER ARM	
3	062711212	1	ナベコ476-32X12	SCREW, PAN SM4.76-32X12	
4	S16641001	2	スタッドL	STUD (L)	
5	062781412	1	ナベコ635-28X14	SCREW, PAN SM6.35-28X14	
6	S16642001	2	スタッドS	STUD (S)	
7	062781012	3	ナベコ635-28X10	SCREW, PAN SM6.35-28X10	
8	S16643009	1	カバー	COVER	
9	062670812	2	ナベコ3.57-40X8	SCREW, PAN SM3.57-40X8	

From the library of: Diabond Needle Corp

877-201-204

G. カマ関係 / Rotary hook mechanism / Greifervorrichtung / Mécanisme du crochet rotatif / Mecanismo del cangrejo

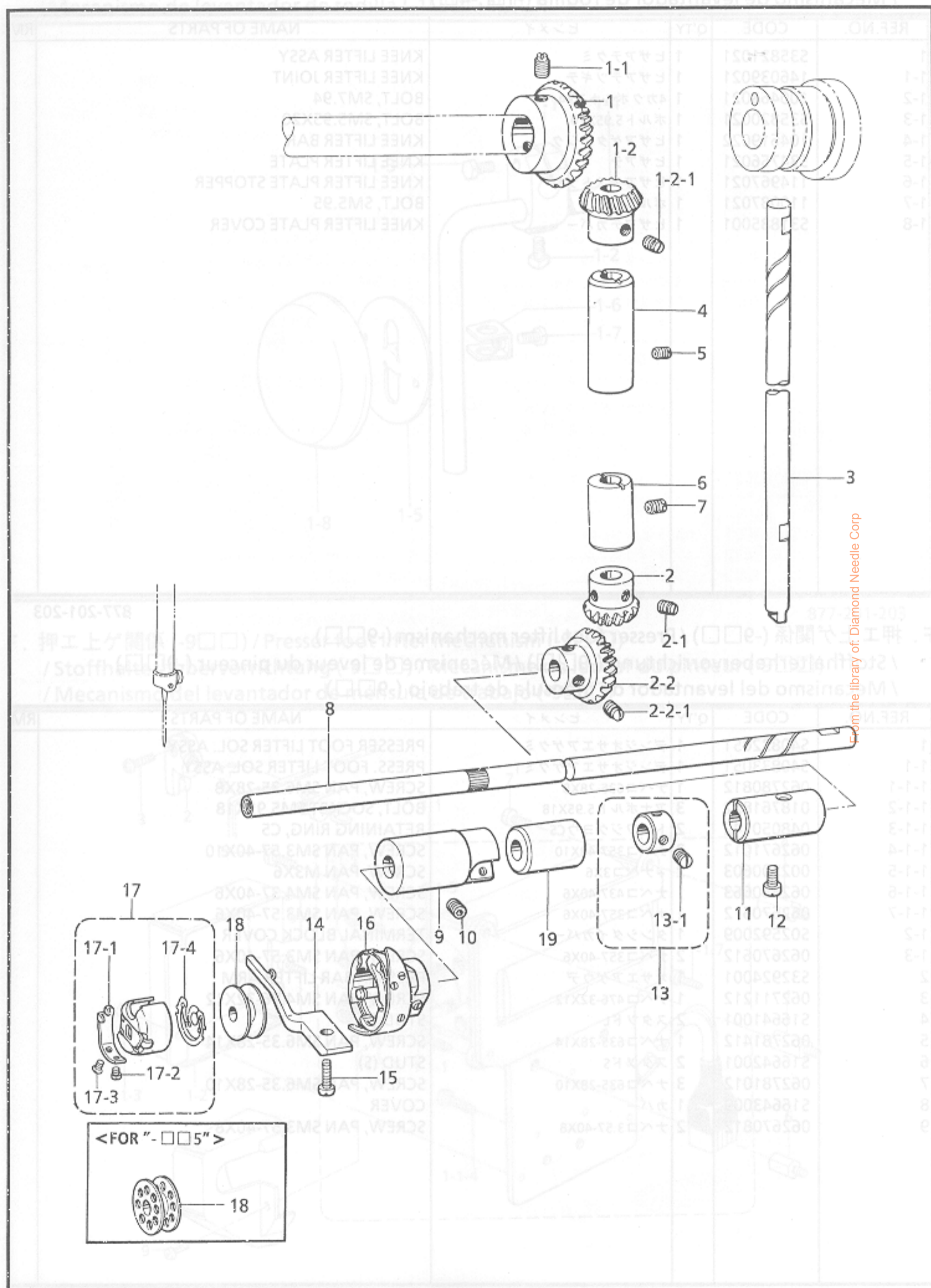

G. カマ関係 / Rotary hook mechanism / Greifervorrichtung / Mécanisme du crochet rotatif / Mecanismo del cangrejo

REF.NO.	CODE	Q'TY	ヒンメイ	NAME OF PARTS	RM
1	180891001	1	ウワジクベベルギヤクミ	UPPER SHAFT BEVEL GEAR ASSY	
1-1	100251001	2	トメネジ6.35	SET SCREW, SM6.35	
1-2	180892001	1	タテジクカサハグルマUクミ	VERTICAL BEVEL GEAR (U) ASSY	
1-2-1	100251001	2	トメネジ6.35	SET SCREW, SM6.35	
2	180885001	1	タテジクカサハグルマDクミ	VERTICAL BEVEL GEAR (D) ASSY	
2-1	100251001	2	トメネジ6.35	SET SCREW, SM6.35	
2-2	180886001	1	シタジクベベルギヤクミ	LOWER SHAFT BEVEL GEAR ASSY	
2-2-1	100251001	2	トメネジ6.35	SET SCREW, SM6.35	
3	145516021	1	タテジク	VERTICAL SHAFT	
4	142708020	1	タテジクメタルU	VERTICAL SHAFT BUSH (D)	
5	013760610	1	トメネジ5.95クボミ	SET SCREW, (CP) SM5.95	
6	S31026020	1	タテジクメタルD	VERTICAL SHAFT BUSH (D)	
7	013761410	1	トメネジ5.95クボミ	SET SCREW, (CP) SM5.95	
8	154552001	1	シタジク	LOWER SHAFT	
9	118761021	1	シタジクメタルL	LOWER SHAFT BUSH (L)	
10	014680622	1	アナトメネジ4.37クボミ	SET SCREW, SOCKET (CP) SM4.37	
11	104520020	1	シタジクメタルR	LOWER SHAFT BUSH (R)	
12	121007001	1	アタマツキトメネジ4.37	SET SCREW, SM4.37	
13	181995021	1	セツトカラークミ	SET SCREW COLLAR ASSY	
13-1	101706001	2	トメネジ6.35	SET SCREW, SM6.35	
15	062681212	1	ナベコ437-40X12	SCREW, PAN SM4.37-40X12	
17	S03245001	1	ボビンケースクミ	BOBBIN CASE ASSY	
17-1	183388001	1	ボビンケースチヨウシバネ	TENSION SPRING	
17-2	183389001	1	チヨウシバネチヨウセツネジ	ADJUST SCREW	
17-3	183390001	1	チヨウシバネトメネジ	SET SCREW	
17-4	S03246001	1	クウテンボウシバネ	BOBBIN TENSION SPRING	
19	S31027020	1	シタジクメタルM	LOWER SHAFT BUSH (M)	
14	S02602021	1	<FOR "-□□1,-□□3"> ウチカマトメ	BOBBIN CASE HOLDER	
16	S06106001	1	<FOR "-□□1"> コウソクカマ	ROTARY HOOK ASSY	
16	S02603101	1	<FOR "-□□3"> コウソクカマ	ROTARY HOOK ASSY	
18	146290001	1	<FOR "-□□1,-□□3"> ボビン	BOBBIN	
14	159324021	1	<FOR "-□□5"> ウチカマトメ	BOBBIN CASE HOLDER	
16	148846001	1	コウソクカマ	ROTARY HOOK ASSY	
18	117132001	1	ボビン	BOBBIN	
21	S164872001	1	オイルジョイント	OIL STOPPER	
22	062670516	1	ナベコ437-40X7	SCREW, PAN SM4.37-40X7	
23	S026091001	1	オイルチューブ	OIL TUBE	
24	S32543001	1	オイルチューブ(D)アッシー	OIL TUBE (D) ASSY	
25	145543001	1	チューブアッシー	TUBE ASSY	
26	145547021	1	チューブホルダー	TUBE HOLDER	
27	062670516	1	ナベコ437-40X5	SCREW, PAN SM3.57-40X5	
28	145737021	1	フェルトサポーター	FELT SUPPORT	
29	145196001	1	オイルストップ	OIL STOPPER	
30	146253000	1	オイルチューブ(L=5)	OIL TUBE (L=5)	
31	081004070	1	OリングP4	O RING, P4	
32	111863001	1	針棒クワ	NEEDLE BAR CORK	
33	108808001	1	ワック(6X6)	WICK (6X6)	
34	S08083000	1	ワック(L=380)	WICK (L=380)	
35	S08004001	1	ワックサポーター	WICK SUPPORT	
36	S32926001	1	オイルストッププレートホルダー	OIL STOPPER PLATE HOLDER	

From the library of: Diamond Needle Corp

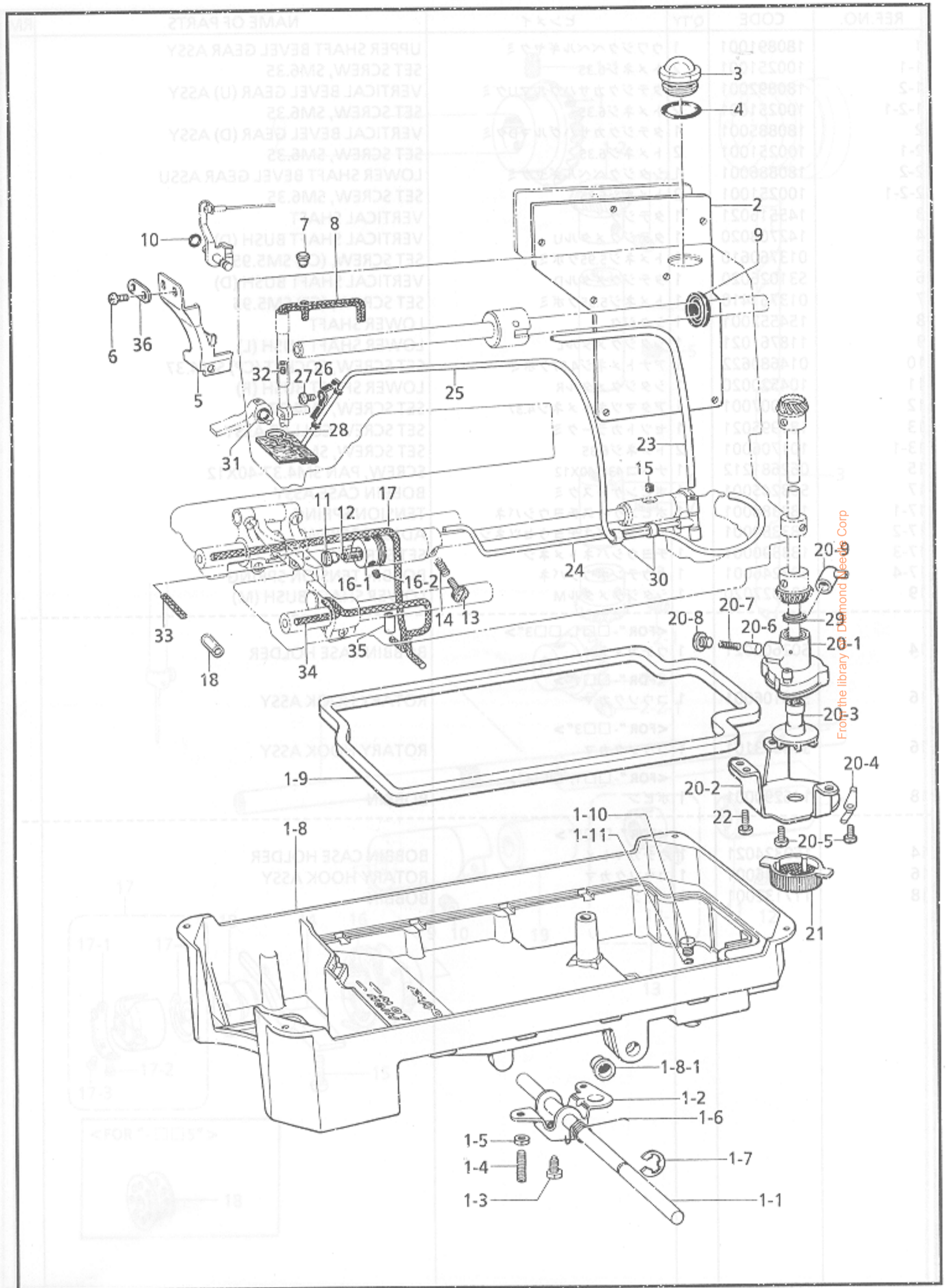

From the library of Diamond Needs Corp

REF.NO.	CODE	Q'TY	ヒンメイ	NAME OF PARTS	RM
1	183496221	1	オイルパンクミ	OIL PAN ASSY (B)	
1-1	146036121	1	ヒザアゲヨコジク	KNEE LIFTER SHAFT	
1-2	S09635021	1	ヒザアゲ	KNEE LIFTER STUD	
1-3	146367021	1	ボルト5.95	BOLT, SM5.95	
1-4	104885121	2	トメネジ5.95	SET SCREW, SM5.95 (B)	
1-5	100022004	2	ナット5.95	NUT, SM5.95 SOCKET (CP) SM4.37	
1-6	S15889021	1	ヒザアゲネジリバネ	TWIST SPRING	
1-7	146293001	1	トメワE10	RETAINING RING, E10	
1-8	149580321	1	オイルパン	OIL PAN	
1-8-1	149578020	2	ヨコジクブツシュ	BUSH	
1-9	146040001	1	オイルパツキング	PACKING	
1-10	140518001	1	シメネジ7.94	SCREW, SM7.94	
1-11	081007070	1	OリングP7	O RING, P7	
2	S28927020	1	ガワイタパツキン	REAR COVER PACKING	
3	S02606000	1	ユリヨウケイマド	OIL GAUGE WINDOW	
4	081014670	1	OリングPW14	O RING, PW14	
5	S32925100	1	テンピンオイルヨケイタ	OIL STOPPER PLATE	
6	062670612	2	ナベコ357-40X6	SCREW, PAN SM3.57-40X6	
7	111865009	1	セン6	CAP, 6	
8	108804001	1	クミヒモ4X4	WICK 4X4 (L = 510)	
9	101487000	1	オイルシール	OIL SEAL	
10	081001670	1	OリングPW1	O RING, PW1	
11	109173101	1	オイルアナフタネジ	OIL CAP SCREW	
12	145751001	1	フェルト	FELT	
13	145534001	1	オイルチヨウセツネジ	ADJUST SCREW	
14	116794001	1	オシバネ	SPRING, COMPRESSION	
15	107155001	1	フェルト	FELT	
16	S06684021	1	カマアブラキリクミ	OIL REJECTOR ASSY	
16-1	S02608021	1	カマアブラキリ	OIL REJECTOR	
16-2	014680422	2	アナトメネジ4.37クボミ	SET SCREW, SOCKET (CP) SM4.37	
17	S40017000	1	クミヒモ360	WICK (L = 360)	
18	S40016001	1	ビニルチューブ2X25	OIL TUBE, 2X25	
20	183850021	1	ポンプタイクミ	PUMP BODY ASSY	
20-1	S32348021	1	ポンプタイ	PUMP BODY	
20-2	144869022	1	ポンプキヤク	PUMP SUPPORT	
20-3	148849021	1	ポンプカイテンヨク	PUMP PROPELLER	
20-4	144874021	2	フィルターバネ	SPRING	
20-5	062670812	4	ナベコ3.57-40X8	SCREW, PAN SM3.57-40X8	
20-6	144875021	1	プランジャー	PLUNGER	
20-7	144876001	1	プランジャーバネ	PLUNGER SPRING	
20-8	112467022	1	シメネジ6.35	SCREW, SM6.35	
20-9	144878001	1	チューブジョイントB	OIL TUBE JOINT (B)	
21	144872121	1	ポンプフィルター	PUMP FILTER	
22	062680712	3	ナベコ437-40X7	SCREW, PAN SM4.37-40X7	
23	S02609100	1	オイルチューブU	OIL TUBE (U)	
24	S32349001	1	オイルチューブDクミ	OIL TUBE (D) ASSY	
25	145543001	1	チューブクミ	TUBE ASSY	
26	145547021	1	チューブホルダ	TUBE HOLDER	
27	062670516	1	ナベコ357-40X5	SCREW, PAN SM3.57-40X5	
28	145737021	1	フェルトオサエ	FELT SUPPORT	
29	146196001	1	アブラヨケ	OIL STOPPER	
30	146253000	2	チューブ	OIL TUBE (L = 5)	
31	081004070	1	OリングP4	O RING, P4	
32	111863001	1	ハリボウセン	NEEDLE BAR CORK	
33	108808001	1	クミヒモ6X6	WICK (6X6)	
34	S08003000	1	クミヒモ	WICK (L = 380)	
35	S08004001	1	クミヒモササエ	WICK SUPPORT	
36	S32926001	1	オイルヨケイタオサエ	OIL STOPPER PLATE HOLDER	

J. 糸通シ関係 / Threading mechanism / Fadenführungsrichtung / Mécanisme de l'enfilage / Mecanismo del enhebrado

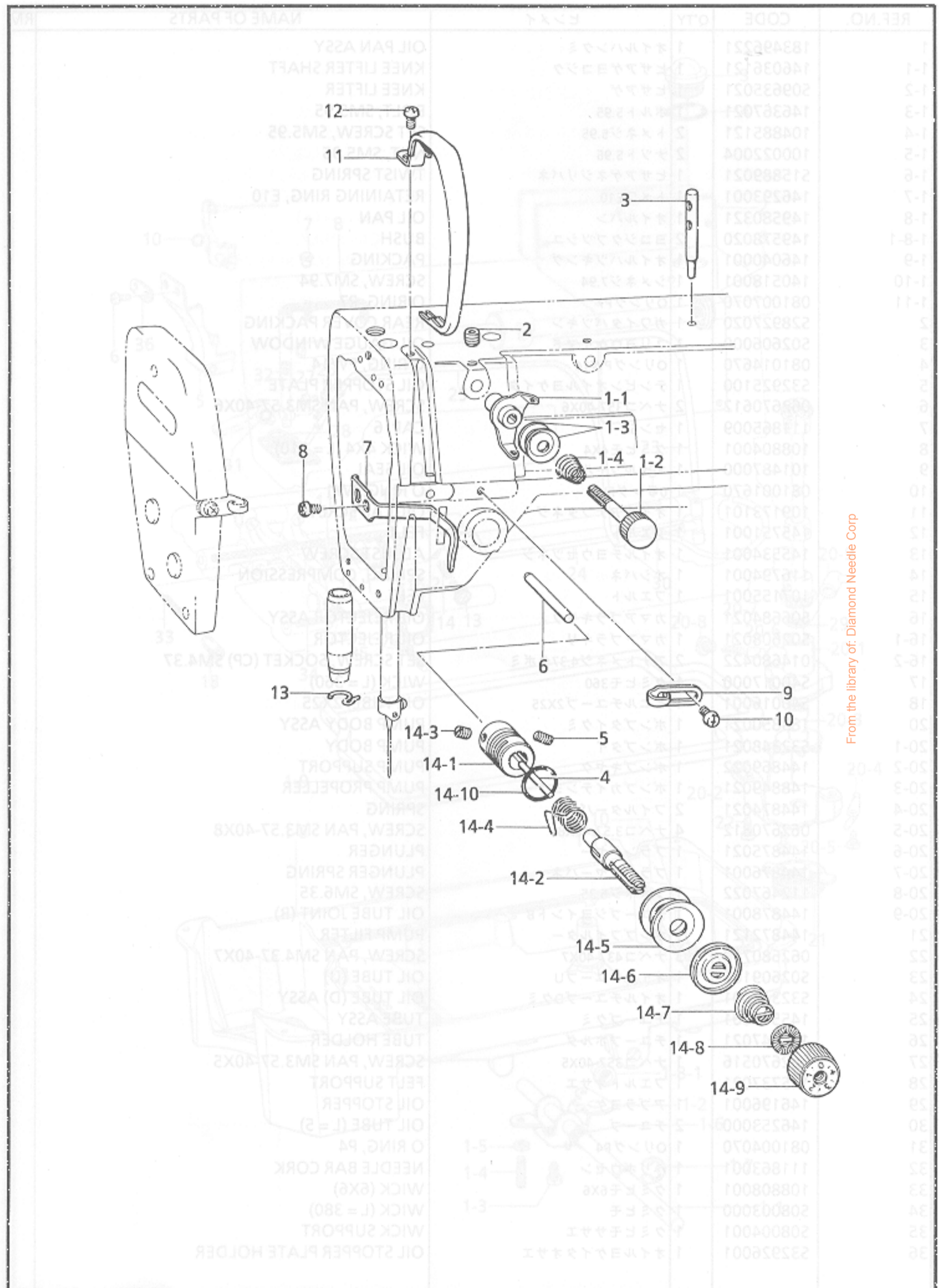

From the library of: Diamond Needle Corp

J. 糸通シ関係 / Threading mechanism / Fadenführungsrichtung / Mécanisme de l'enfilage
 / Mecanismo del enhebrado

REF.NO.	CODE	Q'TY	ヒンメイ	NAME OF PARTS	RM
1	183378001	1	プレテンションクミB	PRE-TENSION ASSY (B)	
1-1	S02611001	1	イトアンナイ	THREAD GUIDE	
1-2	S02612001	1	イトアンナイチヨウシボウ	PRE-TENSION STUD (CP) SM6.35	
1-3	144504001	2	イトアンナイサラ	THREAD GUIDE DISC	
1-4	154562001	1	プレテンションバネB	SPRING, PRE-TENSION (B)	
2	014680622	1	アナトメネジ4.37クボミ	SET SCREW, SOCKET (CP) SM4.37	
3	147557101	1	イトタテボウ	SPOOL PIN	
4	100400000	1	イトユルメピン	PIN	
5	103950003	1	トメネジ5.95	SET SCREW, SM5.95	
6	S07972001	1	イトユルメボウ	TENSION RELEASE STUD	
7	111469101	1	オサエボウダキイトアンナイ	THREAD GUIDE	
8	062680712	1	ナベコ437-40X7	SCREW, PAN SM4.37-40X7	
9	145522001	1	アームイトアンナイR	ARM THREAD GUIDE (R)	
10	S19056001	1	バインド357-40X6	SCREW, BIND M3.57-40X6	
11	S02614124	1	テンピンカバー	THREAD TAKE-UP COVER	
12	062680712	1	ナベコ437-40X7	SCREW, PAN SM4.37-40X7	

13	100573001	1	<FOR "-□□1,-□□3"> ハリボウメタルDイトアンナイ	NEEDLE BAR BUSH (D) THREAD GUI DE	
14	S31031001	1	イトチヨウシボウダイクミ	THREAD TENSION BRACKET ASSY	
14-7	104525001	1	イトチヨウシバネ	TENSION SPRING	
13	148901001	1	<FOR "-□□5"> ハリボウメタルDイトアンナイ	NEEDLE BAR BUSH (D) THREAD GUI DE	
14	S31034001	1	イトチヨウシボウダイクミ	THREAD TENSION BRACKET ASSY	
14-7	S04632001	1	イトチヨウシバネ	TENSION SPRING	

14-1	S03254001	1	イトチヨウシボウタイ	THREAD TENSION BRACKET	
14-2	116922001	1	イトチヨウシボウ	TENSION STUD	
14-3	100402004	1	トメネジ3.57	SET SCREW, SM3.57	
14-4	S02620001	1	イトトリバネ	SPRING	
14-5	145446001	2	イトチヨウシサラ	TENSION DISC	
14-6	159805001	1	イトチヨウシサラオサエ	TENSION DISC PRESSER	
14-8	S12441001	1	チヨウシバネウエザガネ	WASHER	
14-9	S31032001	1	イトチヨウシナツト	TENSION NUT	
14-10	114294001	1	Oリング	O RING	
37	154598001	1	イトクリソレノイドタイ	THREAD TRIMMER SOLENOID BRACKET	
38	T50599000	1	ソレノイドクッション	SOLENOID CUSHION	
39	S02652001	1	ワザガネ	WASHER	
40	S23836001	1	ソレノイドレバークラス	SOLENOID LEVER ASSY	
40-1	014680622	1	アナトメネジ4.37クボミ	SET SCREW, SOCKET (CP) SM4.37	
41	110201001	1	シメネジ6.35	SCREW, SM6.35	
42	S02655002	1	ダンネジ6.35	SCREW, SM6.35	
43	T55559001	1	ワザガネ	WASHER, PLAIN	
45	S02657801	1	コーンホルダ	CORN HOLDER	
46	S33969000	1	ナイロンコネクタ(12P)	NYLON CONNECTOR(12P)	
48	S02688001	1	アース線	GROUND WIRE ASSY	
48-1	S03328000	1	端子ピン(L)(MALE)	TERMINAL PIN (L)(MALE)	
48-2	204569001	1	ワザガネ	WASHER	
49	S02745001	1	ワザガネ	WASHER	
50	062680663	1	ナベコ437-40X6	SCREW, PAN SM4.37-40X6	

From the library of: Diamond Needle Corp

K. 糸切り関係 / Thread trimmer mechanism / Fadenabschneidevorrichtung
 / Mécanisme de coupe-fil / Mecanismo de la cortadura de hiros

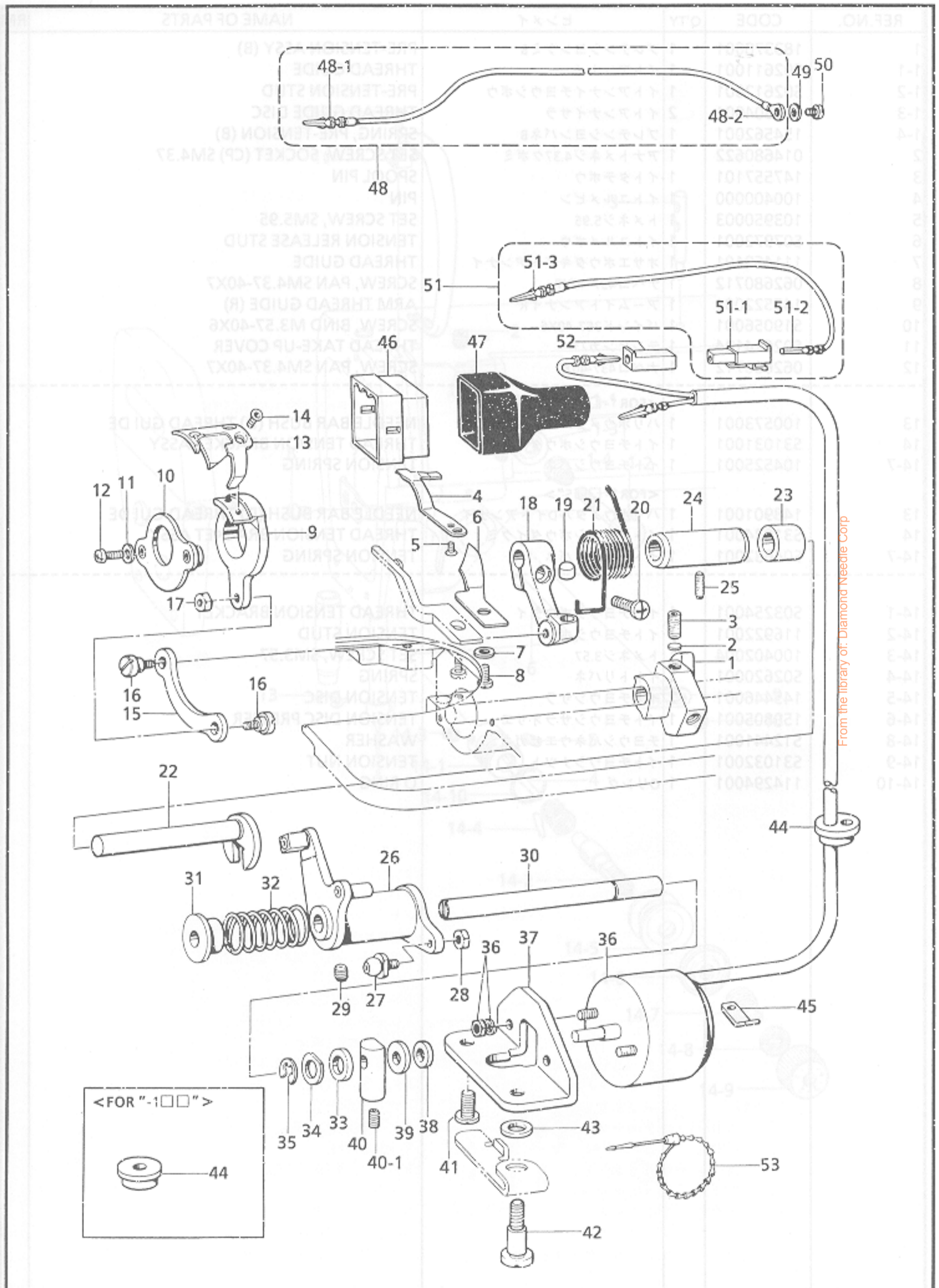

K. 糸切り関係 / Thread trimmer mechanism / Fadenabschneidevorrichtung
 / Mécanisme de coupe-fil / Mecanismo de la cortadura de hiros

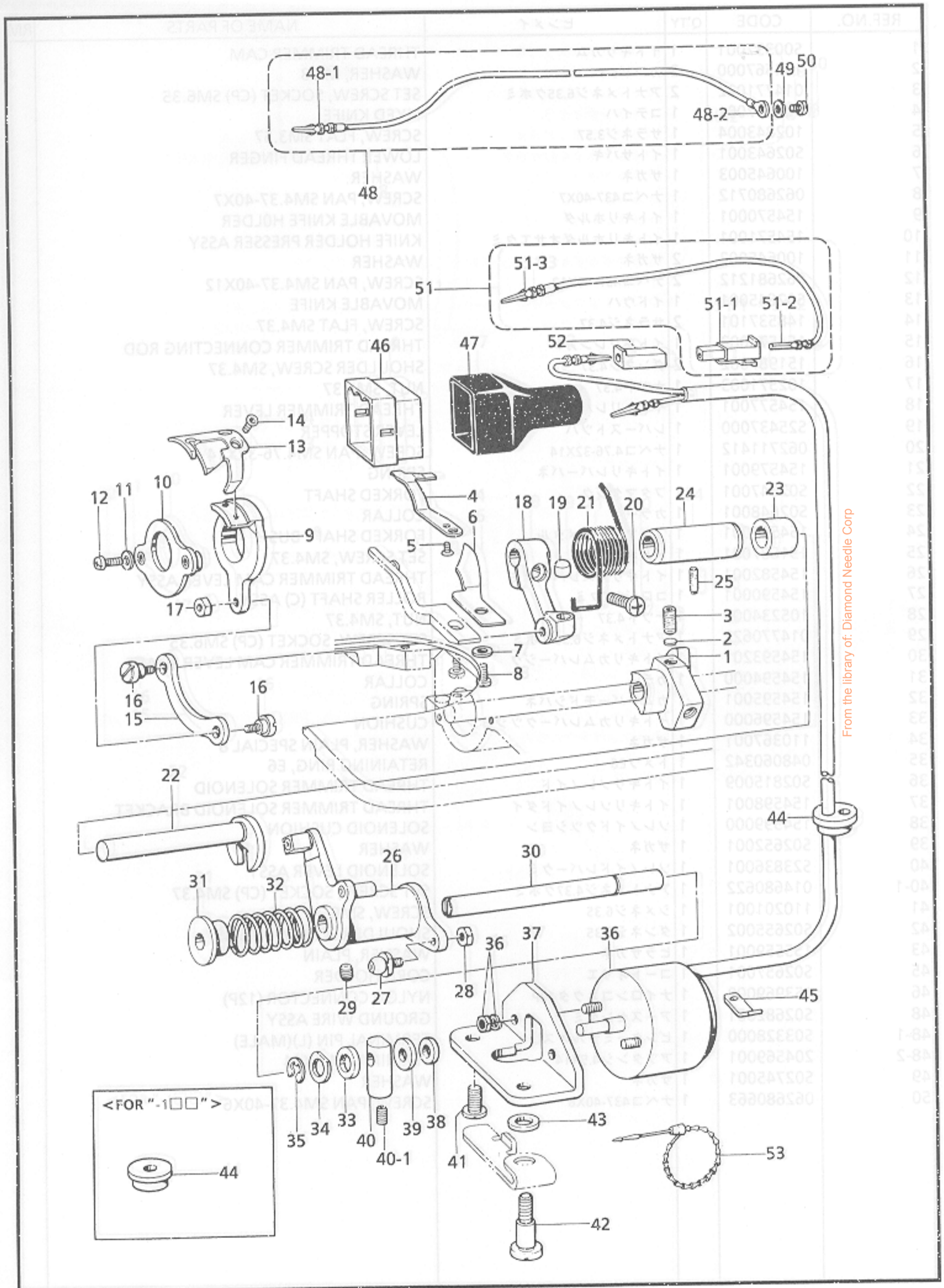

From the library of: Diamond Needle Corp

K. 糸切り関係 / Thread trimmer mechanism / Fadenabschneidevorrichtung
 / Mécanisme de coupe-fil / Mecanismo de la cortadura de hiros

REF.NO.	CODE	Q'TY	ヒンメイ	NAME OF PARTS	RM
1	S00337001	1	イトキリカム	THREAD TRIMMER CAM	
2	154567000	2	カンザ5.3	WASHER, M5.3	
3	014771022	2	アナトメネジ6.35クボミ	SET SCREW, SOCKET (CP) SM6.35	
4	S02637001	1	コテイハ	FIXED KNIFE	
5	102843004	1	サラネジ3.57	SCREW, FLAT SM3.57	
6	S02643001	1	イトサバキ	LOWER THREAD FINGER	
7	100645003	1	ザガネ	WASHER	
8	062680712	1	ナベコ437-40X7	SCREW, PAN SM4.37-40X7	
9	154570001	1	イトキリホルダ	MOVABLE KNIFE HOLDER	
10	154571001	1	イトキリホルダオサエクミ	KNIFE HOLDER PRESSER ASSY	
11	100645003	2	ザガネ	WASHER	
12	062681212	2	ナベコ437-40X12	SCREW, PAN SM4.37-40X12	
13	S02645001	1	イドウハ	MOVABLE KNIFE	
14	148537101	2	サラネジ4.37	SCREW, FLAT SM4.37	
15	154576003	1	イトキリレンカン	THREAD TRIMMER CONNECTING ROD	
16	151987002	2	ダンネジ4.37	SHOULDER SCREW, SM4.37	
17	102571003	1	ナツト4.37	NUT, SM4.37	
18	154577001	1	イトキリレバー	THREAD TRIMMER LEVER	
19	S25437000	1	レバーストツバ	LEVER STOPPER	
20	062711412	1	ナベコ4.76-32X14	SCREW, PAN SM4.76-32X14	
21	154579001	1	イトキリレバーバネ	SPRING	
22	S02647001	1	フタマタジク	FORKED SHAFT	
23	S02648001	1	カラー	COLLAR	
24	154581001	1	フタマタジクメタル	FORKED SHAFT BUSH	
25	151607001	1	トメネジ4.37	SET SCREW, SM4.37	
26	154582001	1	イトキリカムレバークミ	THREAD TRIMMER CAM LEVER ASSY	
27	154590001	1	コロジクCクミ	ROLLER SHAFT (C) ASSY	
28	105234003	1	ナツト4.37	NUT, SM4.37	
29	014770622	1	アナトメネジ6.35クボミ	SET SCREW, SOCKET (CP) SM6.35	
30	154593201	1	イトキリカムレバークミ	THREAD TRIMMER CAM LEVER SHAFT	
31	154594000	1	カラー	COLLAR	
32	154595001	1	カムレバーモドシバネ	SPRING	
33	154596000	1	イトキリカムレバークツシヨン	CUSHION	
34	110367001	1	ザガネ	WASHER, PLAIN SPECIAL 8	
35	048060342	1	トメワE6	RETAINING RING, E6	
36	S02815009	1	イトキリソレノイド	THREAD TRIMMER SOLENOID	
37	154598001	1	イトキリソレノイドダイ	THREAD TRIMMER SOLENOID BRACKET	
38	154599000	1	ソレノイドクツシヨン	SOLENOID CUSHION	
39	S02652001	1	ザガネ	WASHER	
40	S23836001	1	ソレノイドレバークミ	SOLENOID LEVER ASSY	
40-1	014680622	1	アナトメネジ4.37クボミ	SET SCREW, SOCKET (CP) SM4.37	
41	110201001	1	シメネジ6.35	SCREW, SM6.35	
42	S02655002	1	ダンネジ6.35	SHOULDER SCREW, SM6.35	
43	155559001	1	ヒラザガネ	WASHER, PLAIN	
45	S02657001	1	コードオサエ	CORD HOLDER	
46	153969000	1	ナイロンコネクタ12P	NYLON CONNECTOR (12P)	
48	S02682001	1	アースセンクミ	GROUND WIRE ASSY	
48-1	S03328000	1	ピンターミナルオスL	TERMINAL PIN (L)(MALE)	
48-2	204569001	1	アツタンシ4.5X14	TERMINAL, 4.5X14	
49	S02745001	1	ザガネ	WASHER	
50	062680663	1	ナベコ437-40X6	SCREW, PAN SM4.37-40X6	

From the library of: Diamond Needle Corp

K. 糸切り関係 / Thread trimmer mechanism / Fadenabschneidevorrichtung
 / Mécanisme de coupe-fil / Mecanismo de la cortadura de hiros

REF.NO.	CODE	Q'TY	ヒンメイ	NAME OF PARTS	RM
51	S11210000	1	WコードSクミ	W-CORD (S) ASSY	
51-1	S11684000	1	コネクタ3191-01R1	CONNECTOR, (3191-01R1)	
51-2	143548000	1	ピンターミナルメス	TERMINAL PIN (FEMALE)	
51-3	143549000	1	ピンターミナルオス	TERMINAL PIN (MALE)	
52	S11683000	1	コネクタ3191-01P1	CONNECTOR (3191-01P1)	
53	340400001	1	ユニタイバンド	BEAD BAND	
44	157984009	1	<FOR "-1□□"> コードブシユ	CORD BUSH	
47	153970001	1	コネクタキヤツプ3	CONNECTOR CAP 3	
44	146020009	1	<FOR "-4□□,9□□"> コードブシユ	CORD BUSH	
47	S03815001	1	コネクタキヤツプ6	CONNECTOR CAP 6	
1	S02658000	1	イトユルメレバー	TENSION RELEASE WIRE	
2	S02659101	1	イトユルメワイヤー	TENSION RELEASE WIRE	
3	110161004	2	ナベコ3.57-40X8	SCREW, PAN SM3.57-40X8	
4	154606001	1	イトユルメワイヤーホルダD	TENSION RELEASE WIRE HOLDER (D)	
5	062670612	2	ナベコ3.57-40X8	SCREW, PAN SM3.57-40X8	
6	154607001	1	イトユルメワイヤーホルダU	TENSION RELEASE WIRE HOLDER (U)	
7	060670612	2	ナベコ3.57-40X6 S	SCREW, BIND SM3.57-40X6 S	
8	S02660101	1	イトユルメワイヤーホルダE	TENSION RELEASE WIRE HOLDER (E)	
9	062671612	2	ナベコ3.57-40X16	SCREW, PAN SM3.57-40X16	
10	155347001	1	イトユルメワイヤーガイド	TENSION RELEASE WIRE GUIDE	
11	S03670001	1	イトユルメワイヤーガイドバネ	SPRING	

From the library of: Diamond Needle Corp

L. 逆転関係 (-4□□,-9□□) / Quick reverse mechanism (-4□□,-9□□)
 / Umkehr (-4□□,-9□□) / Mécanisme de marche arrière rapide (-4□□,-9□□)
 / Mecanismo de la inversión rápida (-4□□,-9□□)

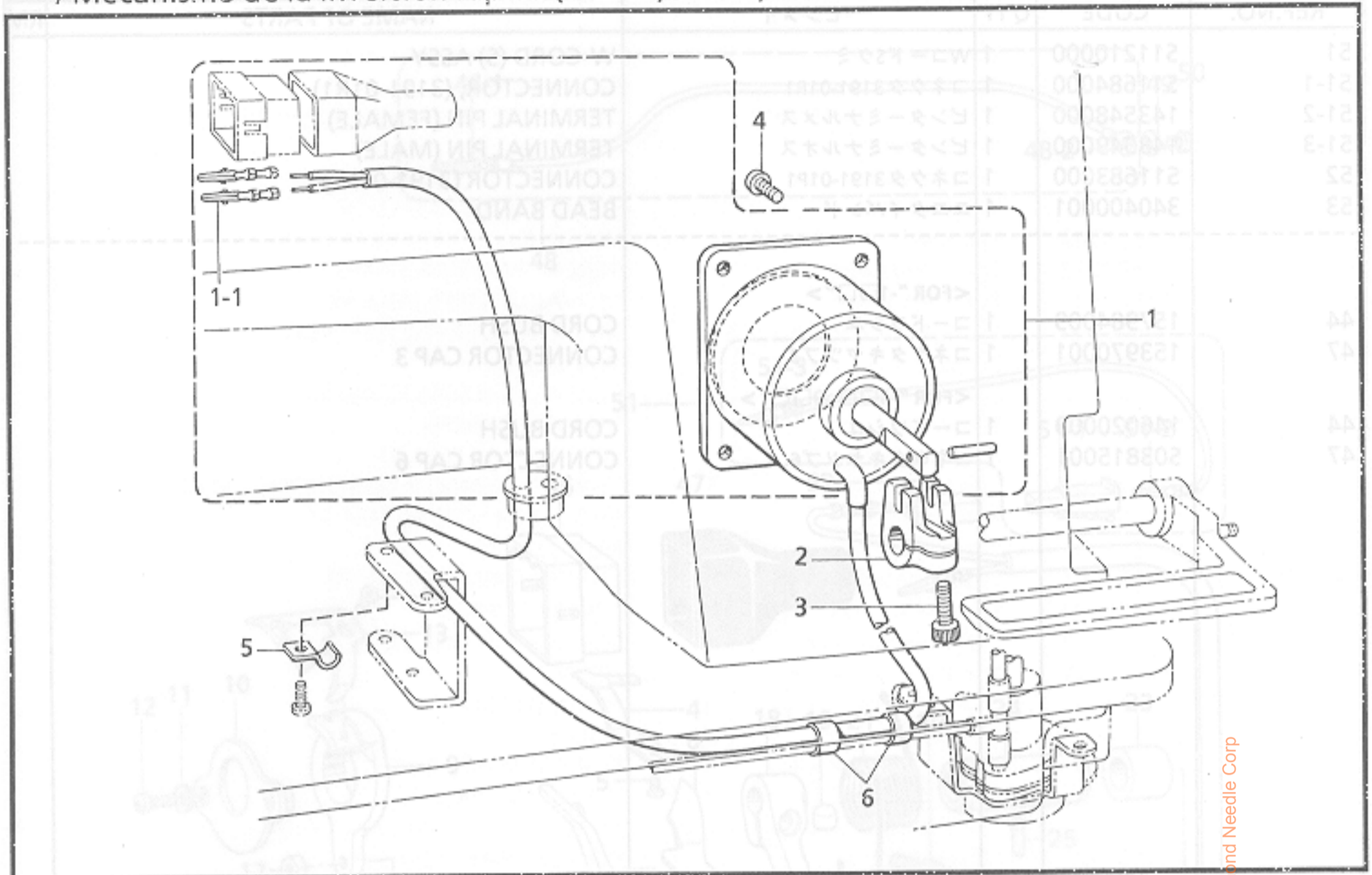

877-201-205

M. 糸緩メ関係 / Tension release mechanism / Spannungsverminderungsvorrichtung
 / Mécanisme de la lâche de tension / Mecanismo relajador de tensión

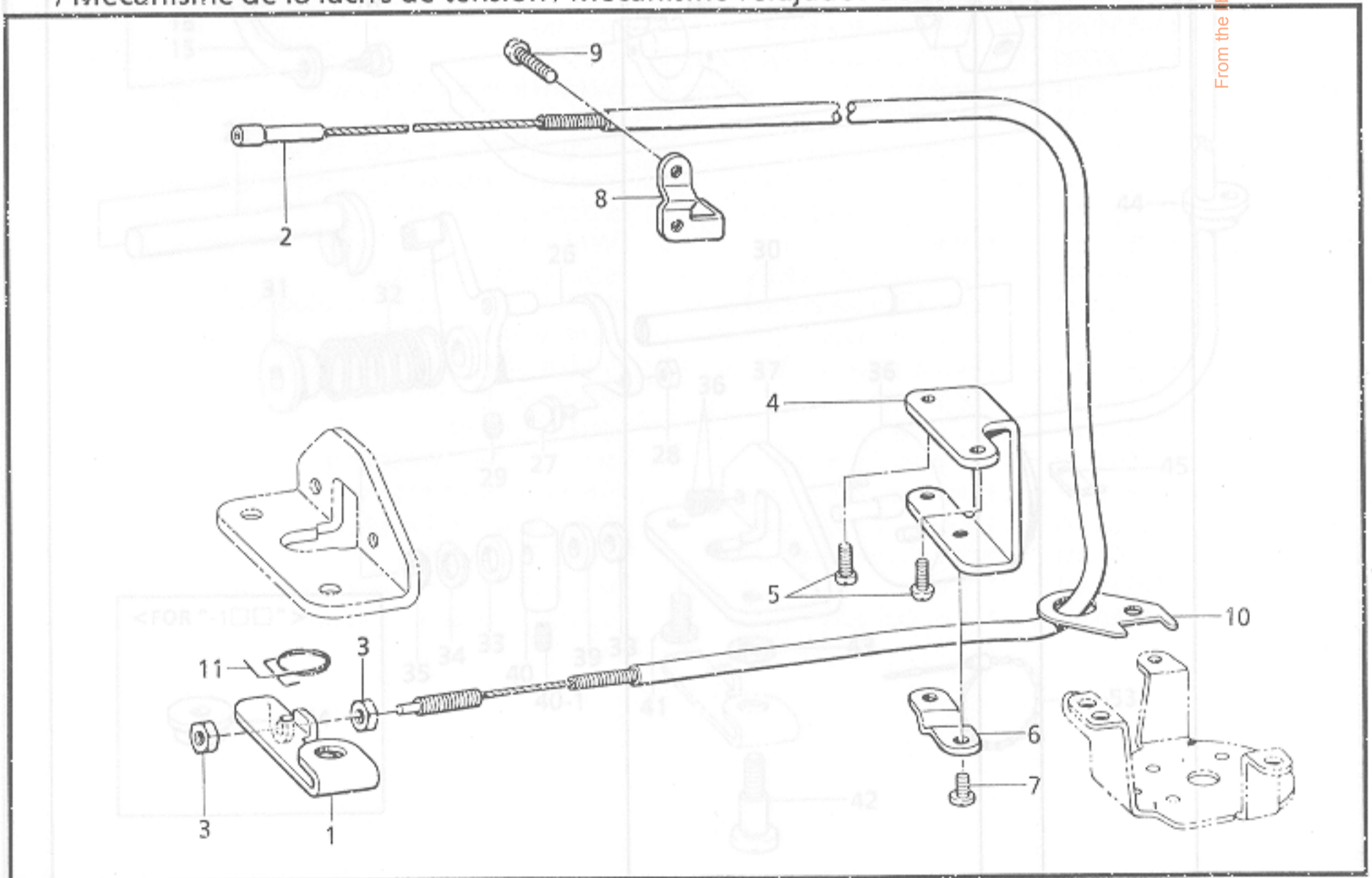

877-201-404

From the library of: Diamond Needle Corp

L. 逆転関係 (-4□□,-9□□) / Quick reverse mechanism (-4□□,-9□□)
 / Umkehr (-4□□,-9□□) / Mécanisme de marche arrière rapide (-4□□,-9□□)
 / Mecanismo de la inversión rápida (-4□□,-9□□)

REF.NO.	CODE	Q'TY	ヒンメイ	NAME OF PARTS	RM
1	S02597009	1	ギャクテンソレノイドクミ	QUICK REVERSE SOLENOID ASSY	
1-1	143549000	2	ピンターミナルオス	TERMINAL PIN (MALE)	
2	S02600000	1	ソレノイドレバー	SOLENOID LEVER	
3	S07959001	1	アナホルト476-32X14	BOLT, SOCKET SM4.76-32X14	
4	062711012	4	ナベコ476-32X10	SCREW, PAN SM4.76-32X10	
5	140647001	1	コードオサエ	CORD HOLDER	
6	146253000	2	チューブ	OIL TUBE (L = 5)	
7	062300616	3	ナベコM3X6	SCREW, PAN M3X6	
8	140647001	1	コードオサエ	CORD HOLDER	
9	062300616	2	ナベコM3X6	SCREW, PAN M3X6	
10	S33609001	1	ソレノイドトリツケタイ	SOLENOID SETTING BRACKET	
11	062681012	2	ナベコ437-40X10	SCREW, PAN SM4.37-40X10	
12	062300616	2	ナベコM4X6	SCREW, PAN M4X6	
13	079400000	1	ワッシャー	WASHER FLAIN	
14	S33610001	1	ソレノイドカバー	SOLENOID COVER	
15	060400516	1	バインドM4X5	SCREW, BIND M4X5	
16	S02672002	1	スレッドワイパーサポート	THREAD WIPER SUPPORT	
17	S25452001	1	スレッドワイパーリンククミ	THREAD WIPER LINK ASSY	
18	048040352	1	リテーニングリング	RETAINING RING, E4	
19	S25454001	1	セットカラー	SET SCREW COLLAR	
20	S25279001	1	セットネジ(CP)M3.5-5	SET SCREW (CP) M3.5-5	
21	S02678001	1	スプリング	SPRING	
22	S02679002	1	スレッドワイパーリンク	THREAD WIPER LINK	
23	110735002	1	ワッシャー	WASHER	

877-201-205

M. 糸緩メ関係 / Tension release mechanism / Spannungsverminderungsrichtung
 / Mécanisme de la lâche de tension / Mecanismo relajador de tensión

REF.NO.	CODE	Q'TY	ヒンメイ	NAME OF PARTS	RM
1	S02658000	1	イトユルメレバー	TENSION RELEASE WIRE	
2	S02659101	1	イトユルメワイヤー	TENSION RELEASE WIRE	
3	110161004	2	ナツト4.76	NUT, SM4.76	
4	154606001	1	イトユルメワイヤーホルダD	TENSION RELEASE WIRE HOLDER (D)	
5	062670812	2	ナベコ3.57-40X8	SCREW, PAN SM3.57-40X8	
6	154607001	1	イトユルメワイヤーオサエD	TENSION RELEASE WIRE HOLDER (D)	
7	060670612	2	バインド357-40X6	SCREW, BIND SM3.57-40X6	
8	S02660101	1	イトユルメワイヤーオサエU	TENSION RELEASE WIRE HOLDER (U)	
9	062671612	2	ナベコ357-40X16	SCREW, PAN SM3.57-40X16	
10	155347001	1	イトユルメワイヤーアンナイ	TENSION RELEASE WIRE GUIDE	
11	S03670001	1	イトユルメモドシバネ	SPRING	

877-201-404

N. 糸払イ関係 (-4□□,-9□□) / Thread wiper mechanism (-4□□,-9□□)
 / Fadenwischvorrichtung (-4□□,-9□□) / Mécanisme de tire-fil (-4□□,-9□□)
 / Mecanismo del limpiador de hilo (-4□□,-9□□)

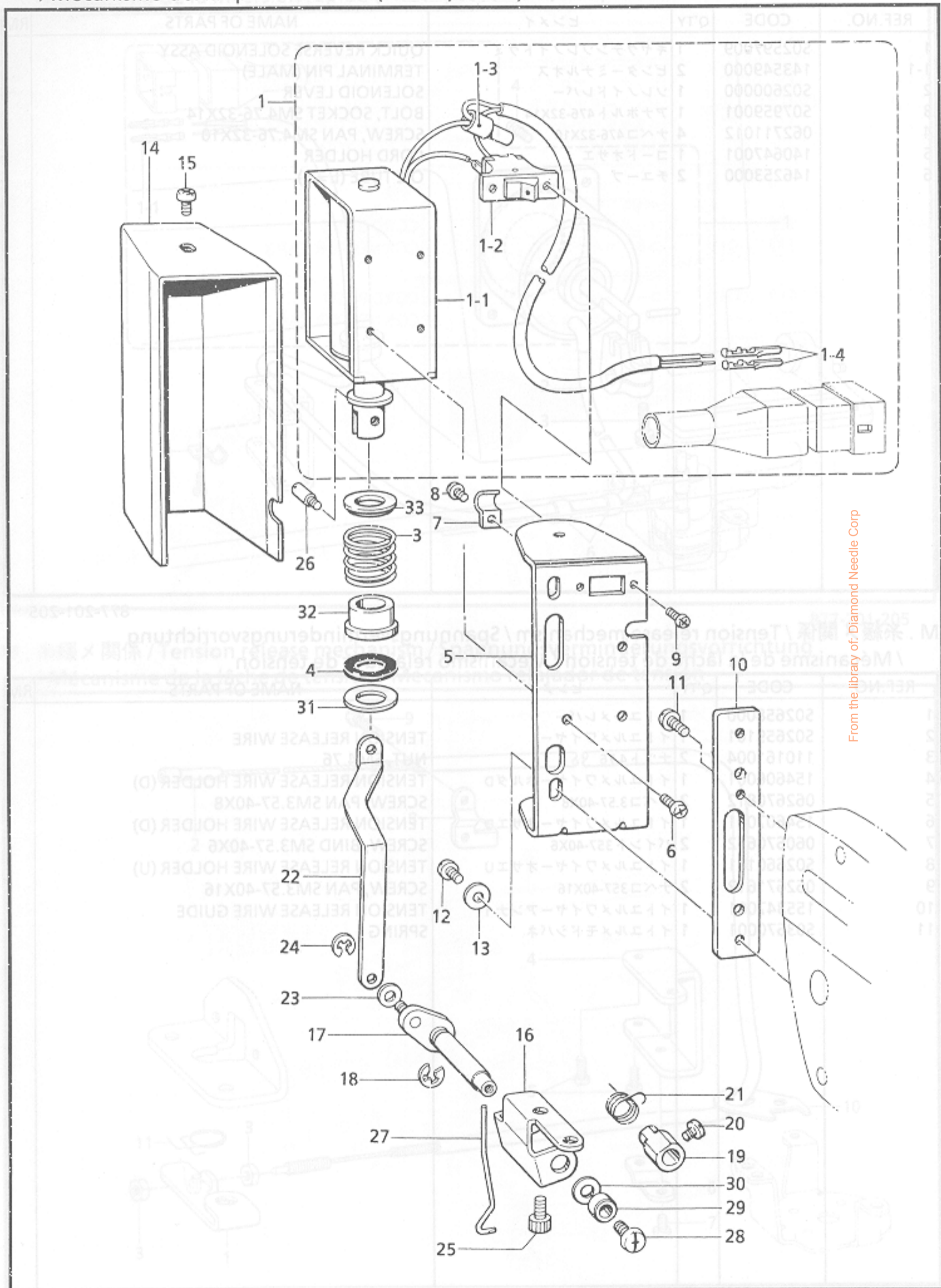

From the library of: Diamond Needle Corp

N. 糸払イ関係 (-4□□,-9□□) / Thread wiper mechanism (-4□□,-9□□)
 / Fadenwischvorrichtung (-4□□,-9□□) / Mécanisme de tire-fil (-4□□,-9□□)
 / Mecanismo del limpiador de hilo (-4□□,-9□□)

REF.NO.	CODE	Q'TY	品名	NAME OF PARTS	RM
1	S34112001	1	イトハライソレノイドクミ	THREAD WIPER SOLENOID ASSY	
1-1	S33608001	1	イトハライソレノイド	THREAD WIPER SOLENOID	
1-2	S02664001	1	イトハライスイッチ	THREAD WIPER SWITCH	
1-3	S02665000	1	ヘイタンセツゾクシ	CONNECTOR	
1-4	143549000	2	ピンターミナルオス	TERMINAL PIN (MALE)	
3	S33612001	1	イトハライバネ	THREAD WIPER SPRING	
4	S02668000	1	プランジャーゴム	PLUNGER STOPPER	
5	S25449101	1	ソレノイドトリツケイタ	SOLENOID SETTING PLATE	
6	062300616	3	ナベコM3X6	SCREW, PAN M3X6	
7	140647001	1	コードオサエ	CORD HOLDER	
8	062300616	1	ナベコM3X6	SCREW, PAN M3X6	
9	062300616	2	ナベコM3X6	SCREW, PAN M3X6	
10	S33609001	1	ソレノイドトリツケダイ	SOLENOID SETTING BRACKET	
11	062681012	2	ナベコ437-40X10	SCREW, PAN SM4.37-40X10	
12	062400616	2	ナベコM4X6	SCREW, PAN M4X6	
13	026040236	2	ヒラザガネミガキ4	WASHER, PLAIN 4	
14	S33610001	1	ソレノイドカバー	SOLENOID COVER	
15	060400516	1	バインドM4X5	SCREW, BIND M4X5	
16	S02672002	1	イトハライジクウケイタ	THREAD WIPER SUPPORT	
17	S25452001	1	イトハライクランククミ	THREAD WIPER CRANK ASSY	
18	048040342	1	トメワE4	RETAINING RING, E4	
19	S25454001	1	セツトカラー	SET SCREW COLLAR	
20	S25279001	1	アタマトメクボミM35-5	SET SCREW, (CP) M35-5	
21	S02678001	1	ワイパーバネ	SPRING	
22	S02679002	1	イトハライロツド	THREAD WIPER LINK	
23	110735002	1	ザガネ	WASHER	
24	048030342	1	トメワE3	RETAINING RING, E3	
25	018680822	2	アナボルト4.37X8	BOLT, SOCKET SM4.37X8	
26	S25456001	1	プランジャピン	PLUNGER PIN	
27	S02681001	1	イトハライ	THREAD WIPER	
28	060400516	1	バインドM4X5	SCREW, BIND M4X5	
29	146288001	1	イトハライジクカラー	THREAD WIPER STUD COLLAR	
30	S03677001	1	ザガネ	WASHER	
31	S15589000	1	スペーサ	SPACER	
32	S33611001	1	スリーブ	SLEEVE	
33	S33613001	1	スペーサ	SPACER	

From the library of: Diamond Needle Corp

P. 針位置検出器関係 / Synchronizer / Synchronisator / Synchronisateur / Sincronizador

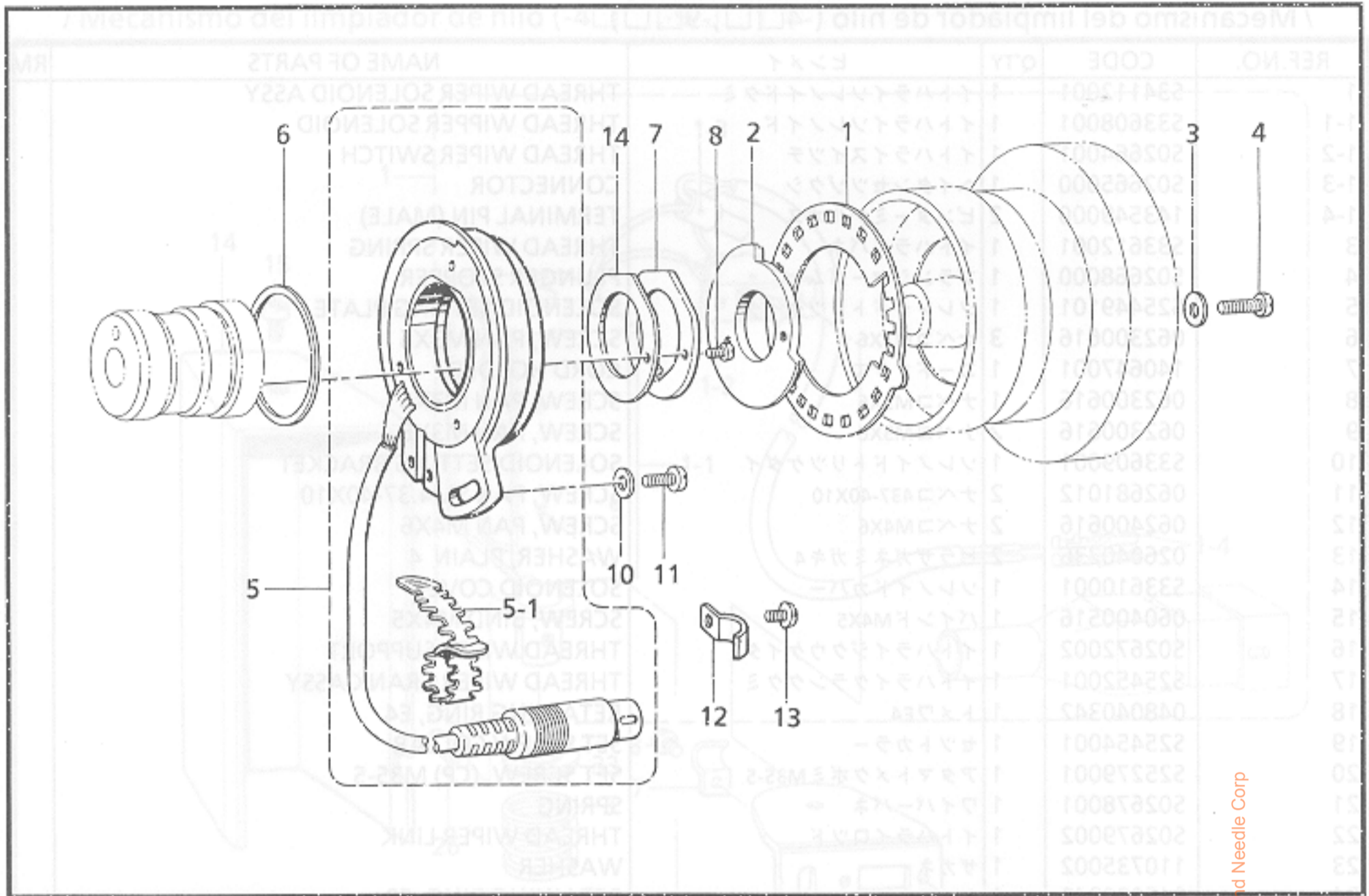

877-201-501

Q. コントロールボックス関係 / Control box mechanism / Schaltkasten / Mécanisme du boîtier de contrôle / Mecanismo de la caja de controles

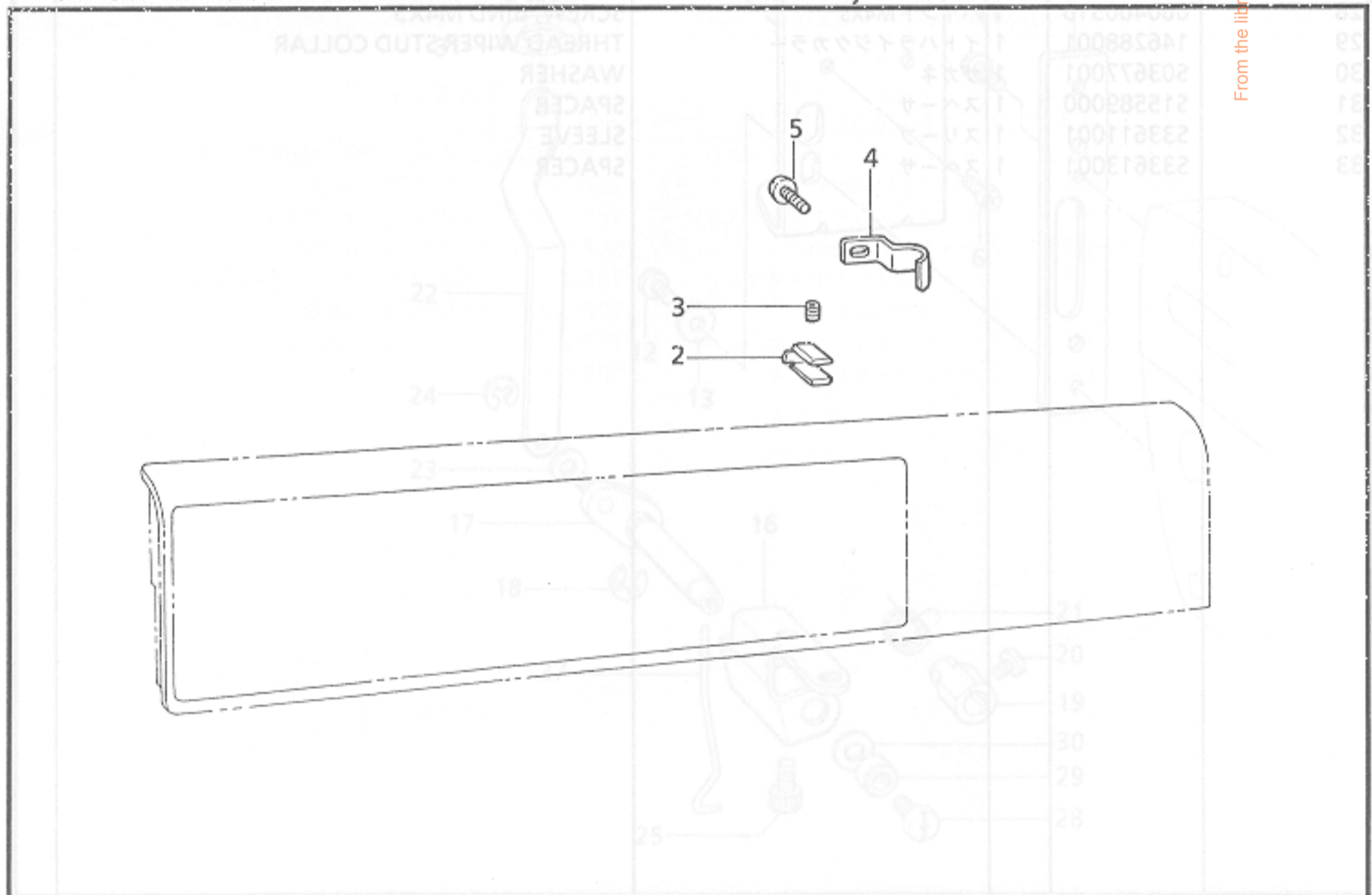

From the library of: Diamond Needle Corp

P. 針位置検出器関係 / Synchronizer / Synchronisator / Synchronisateur / Sincronizador

REF.NO.	CODE	Q'TY	ヒンメイ	NAME OF PARTS	RM
1	S02684101	1	ソクドシレイイタ24	SPEND COMMAND PLATE, 24	
2	S02685001	1	ハリウエイタ	NEEDLE UPPER PLATE	
3	100645003	2	ザガネ	WASHER	
4	062681612	2	ナベコ437-40X16	SCREW, PAN SM4.37-40X16	
5	237939001	1	シンクロナイザクミ#13G2	SYNCHRONIZER ASSY #13G2	
5-1	228475000	1	ケツソクバンド1.9X80	FASTENING BAND, 1.9X80	
6	S03327000	1	シンクロナイザパツキン	SYNCHRONIZER PACKING	
7	S02687201	1	ケンシュツキオサエ	SYNCHRONIZER SUPPORT	
8	062630712	2	ナベコ238-56X7	SCREW, PAN SM2.38X7	
10	113431002	1	ザガネ	WASHER	
11	062711012	1	ナベコ476-32X10	SCREW, PAN SM4.76-32X10	
12	140647001	1	コードオサエ	CORD HOLDER	
13	062670612	1	ナベコ357-40X6	SCREW, PAN SM3.57-40X6	
14	S28926020	1	ケンシュツキオサエパツキン	SYNCHRONIZER SUPPORT PACKING	
1-1-1	062670612	2	ナベコ357-40X6	SCREW, PAN SM3.57-40X6	
1-1-1-1	062670612	2	ナベコ357-40X6	SCREW, PAN SM3.57-40X6	
1-1-1-2	062670612	2	ナベコ357-40X6	SCREW, PAN SM3.57-40X6	
1-1-1-3	062670612	2	ナベコ357-40X6	SCREW, PAN SM3.57-40X6	
1-1-1-4	062670612	2	ナベコ357-40X6	SCREW, PAN SM3.57-40X6	
1-1-1-5	062670612	2	ナベコ357-40X6	SCREW, PAN SM3.57-40X6	
1-1-1-6	062670612	2	ナベコ357-40X6	SCREW, PAN SM3.57-40X6	
1-1-1-7	062670612	2	ナベコ357-40X6	SCREW, PAN SM3.57-40X6	
1-2	S32924001	1	オサエアダ	PRESSER BAR LIFTER ARM 01-1	
1-3	062711212	1	ナベコ476-32X10	SCREW, PAN SM4.76-32X10	
1-4	S16641001	2	スチール	STEEL (S)	
1-5	062781412	1	ナベコ635-28X14	SCREW, PAN SM6.35-28X14	
1-6	S16642001	1	ゴタツク	STUD (S)	
1-7	062781412	3	ナベコ635-28X10	SCREW, PAN SM6.35-28X10	
1-8	S16643009	1	カバー	COVER	
1-9	062670812	2	ナベコ357-40X8	SCREW, PAN SM3.57-40X8	
1-10	S16643002	1	カバー	BEAR COVER ASSY	

From the library of: Diamond Needle Corp

877-201-501

Q. コントロールボックス関係 / Control box mechanism / Schaltkasten / Mécanisme du boîtier de contrôle / Mecanismo de la caja de controles

REF.NO.	CODE	Q'TY	ヒンメイ	NAME OF PARTS	RM
2 10-5	S34448001	2	パネルシジダイ	PANEL SUPPORT BRACKET	
3 10-6	014680622	2	アナトメネジ4.37クボミ	SET SCREW, SOCKET (CP) SM4.37	
4 10-7	S11308001	1	コードホルダ	CORD HOLDER	
5	060670612	1	バインド357-40X6	SCREW, BIND SM3.57-40X6	
1-11	S07045009	1	ヒザスイッチ	KNEE SWITCH ASSY	
1-11-1	142026003	1	ヒザスイッチシャフト	KNEE SWITCH SHAFT	
1-11-2	142027001	1	ヒザスイッチシャフトブラケット	KNEE SWITCH SHAFT BRACKET	
1-11-3	S00383001	1	ボルト	BOLT, SM7.94	
1-11-4	06067001	1	ヒザスイッチストップ	KNEE SWITCH PLATE STOPPER	
1-11-5	S110087001	1	ボルト	BOLT, SM5.95	
1-11-6	S07027001	1	ヒザスイッチプレート	KNEE SWITCH PLATE	
1-11-7	062670612	4	ナベコ	SCREW, PAN M4X10	
1-11-8	025040233	4	ワッシャー	WASHER, PLAIN M4	
1-11-9	028040243	4	ワッシャー	WASHER, SPRING 2-4	
1-11-10	060670612	4	ナベコ	SCREW, PAN M4	
1-11-11	S07030009	1	スイッチコード	SWITCH CORD ASSY	
1-11-12	149799000	1	ビーズ	BEAD BAND (S)	
1-12	034422503	4	ナベコ	WOOD SCREW, FLAT M4, 1X25	

877-201-502

- R. 電磁押エ上ゲ関係 (オプション部品<-1□□,-4□□>)
 / Presser foot lifting solenoid set (Option parts<-1□□,-4□□>)
 / Solenoidsatz für die anhebung des stoffdrückerfußes (Sonderzubehör<-1□□,-4□□>)
 / Conjunto aéreo del levantador del pie (Pièces en option<-1□□,-4□□>)
 / Conjunto solenoide del levantador (Piezas opciona<-1□□,-4□□>)

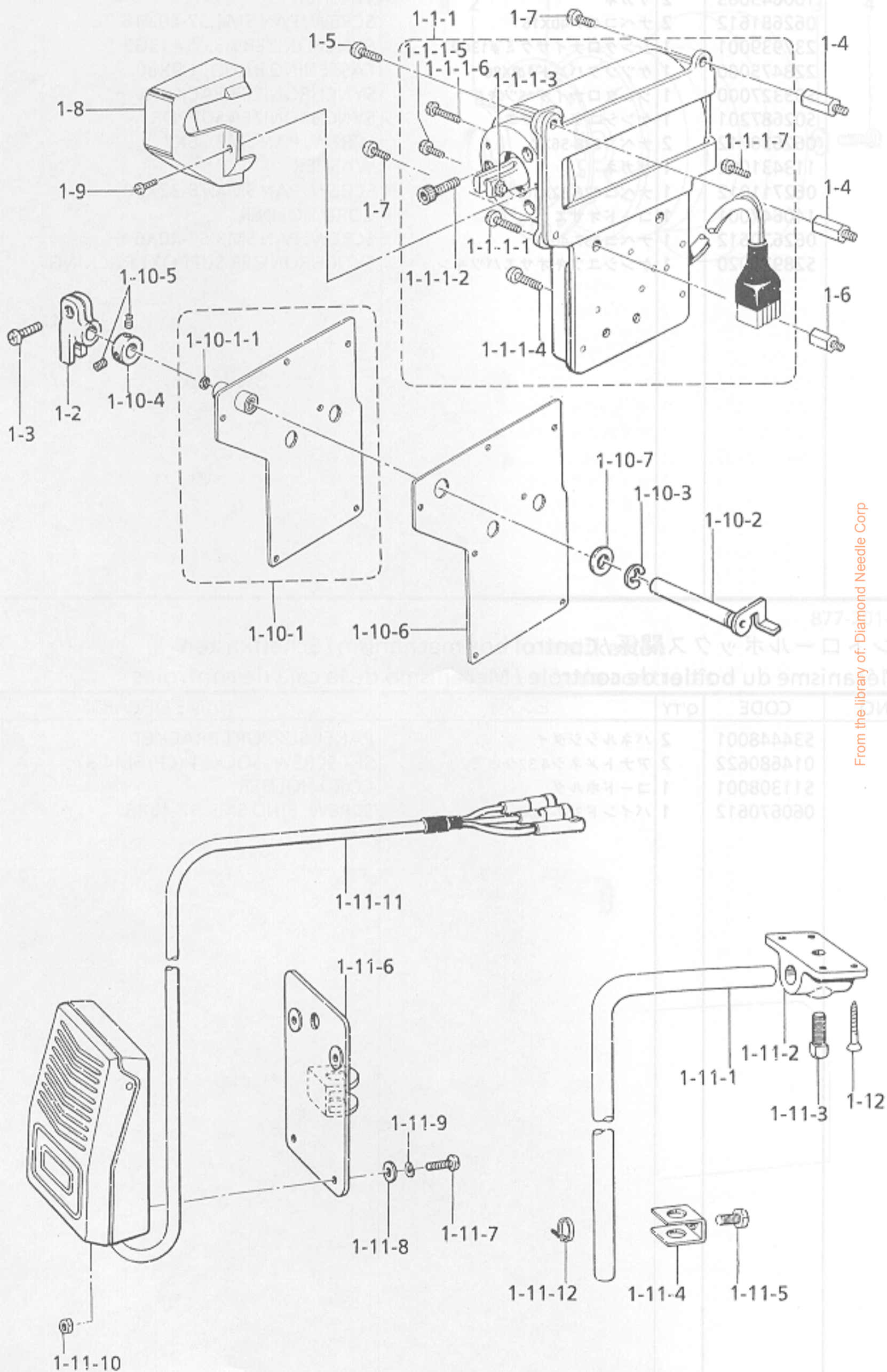

From the library of: Diamond Needle Corp

R. 電磁押上ゲ関係 (オプション部品<-1□□,-4□□>)

/ Presser foot lifting solenoid set (Option parts<-1□□,-4□□>)

/ Solenoidsatz für die anhebung des stoffdrückerfußes (Sonderzubehör<-1□,-4□□>)

/ Conjunto aéreo del levantador del pie (Pièces en option<-1□□,-4□□>)

/ Conjunto solenoide del levantador (Piezas opcionales<-1□□,-4□□>)

REF.NO.	CODE	Q'TY	ヒンメイ	NAME OF PARTS	RM
1	183947001	1	<With "Knee switch assy"> デンジオサエアゲセットA	PRES. FOOT LIFTER SOL. SET A	
1	183948001	1	<With-out "Knee switch assy"> デンジオサエアゲセットB	PRES. FOOT LIFTER SOL. SET B	
1-1	S40832051	1	デンジオサエアゲクミ	PRESSER FOOT LIFTER SOL. ASSY	
1-1-1	S40833051	1	デンジオサエアゲクミT	PRESSER FOOT LIFTER SOL. ASSY	
1-1-1-1	062780812	1	ナベコ635-28X8	SCREW, PAN SM6.35-28X8	
1-1-1-2	018761822	3	アナボルト5.95X18	BOLT, SOCKET SM5.95X18	
1-1-1-3	048050142	2	トメワジクヨウC5	RETAINING RING, C5	
1-1-1-4	062671012	2	ナベコ357-40X10	SCREW, PAN SM3.57-40X10	
1-1-1-5	002300603	1	+ナベコ3X6	SCREW, PAN M3X6	
1-1-1-6	062680663	1	ナベコ437-40X6	SCREW, PAN SM4.37-40X6	
1-1-1-7	062670612	1	ナベコ357-40X6	SCREW, PAN SM3.57-40X6	
1-2	S32924001	1	オサエアゲウデ	PRESSER BAR LIFTER ARM	
1-3	062711212	1	ナベコ476-32X12	SCREW, PAN SM4.76-32X12	
1-4	S16641001	2	スタツドL	STUD (L)	
1-5	062781412	1	ナベコ635-28X14	SCREW, PAN SM6.35-28X14	
1-6	S16642001	2	スタツドS	STUD (S)	
1-7	062781012	3	ナベコ635-28X10	SCREW, PAN SM6.35-28X10	
1-8	S16643009	1	カバー	COVER	
1-9	062670812	2	ナベコ3.57-40X8	SCREW, PAN SM3.57-40X8	
1-10	S16644102	1	トウブデンジガワイタ	REAR COVER	
1-10-1	S16615002	1	ガワイタソウクミ	REAR COVER ASSY	
1-10-1-1	S11589000	1	ダストシール	DUST SEAL	
1-10-2	S32923001	1	オサエアゲジク	PRESSER BAR SHAFT	
1-10-3	048080342	1	トメワE8	RETAINING RING, E8	
1-10-4	110197001	1	セットカラー	SET SCREW COLLAR	
1-10-5	153675001	2	アナトメネジ4.37	SET SCREW, SOCKET M4.37	
1-10-6	S16645000	1	ガワイタパツキン	REAR COVER PACKING	
1-10-7	025100132	1	ヒラザガネシヨウ10	WASHER, PLAIN S 10	
1-11	S07045009	1	<FOR "SET B"> ヒザスイッチクミ	KNEE SWITCH ASSY	
1-11-1	142026003	1	ヒザスイッチタテジク	KNEE SWITCH SHAFT	
1-11-2	142027001	1	ヒザスイッチタテジクウケ	KNEE SWITCH SHAFT BRACKET	
1-11-3	100463001	1	カクボルト7.94	BOLT, SM7.94	
1-11-4	114967001	1	ヒザアテストツバ	KNEE LIFTER PLATE STOPPER	
1-11-5	110087001	1	ボルト5.95	BOLT, SM5.95	
1-11-6	S07027001	1	ヒザスイッチトリツケイタ	KNEE LIFTER SWITCH PLATE	
1-11-7	062401006	4	ナベコ4X10	SCREW, PAN M4X10	
1-11-8	025040233	4	ヒラザガネチユウ4	WASHER, PLAIN M 4	
1-11-9	028040243	4	バネザガネ2-4	WASHER, SPRING 2-4	
1-11-10	021400164	4	ナツト1シユ4	NUT, 1 M4	
1-11-11	S07030009	1	スイッチコードクミ	SWITCH CORD ASSY	
1-11-12	149799000	1	タイラツプS	BEAD BAND (S)	
1-12	034422503	4	+サラモクネジ4.1X25	WOOD SCREW, FLAT M4.1X25	

From the library of: Diamond Needle Corp

S. オプション部品関係 (新素材用) / Attachment set (For "Shin-gosen") / Anbausatz / Jeu d'accessoires / Juego de fijación

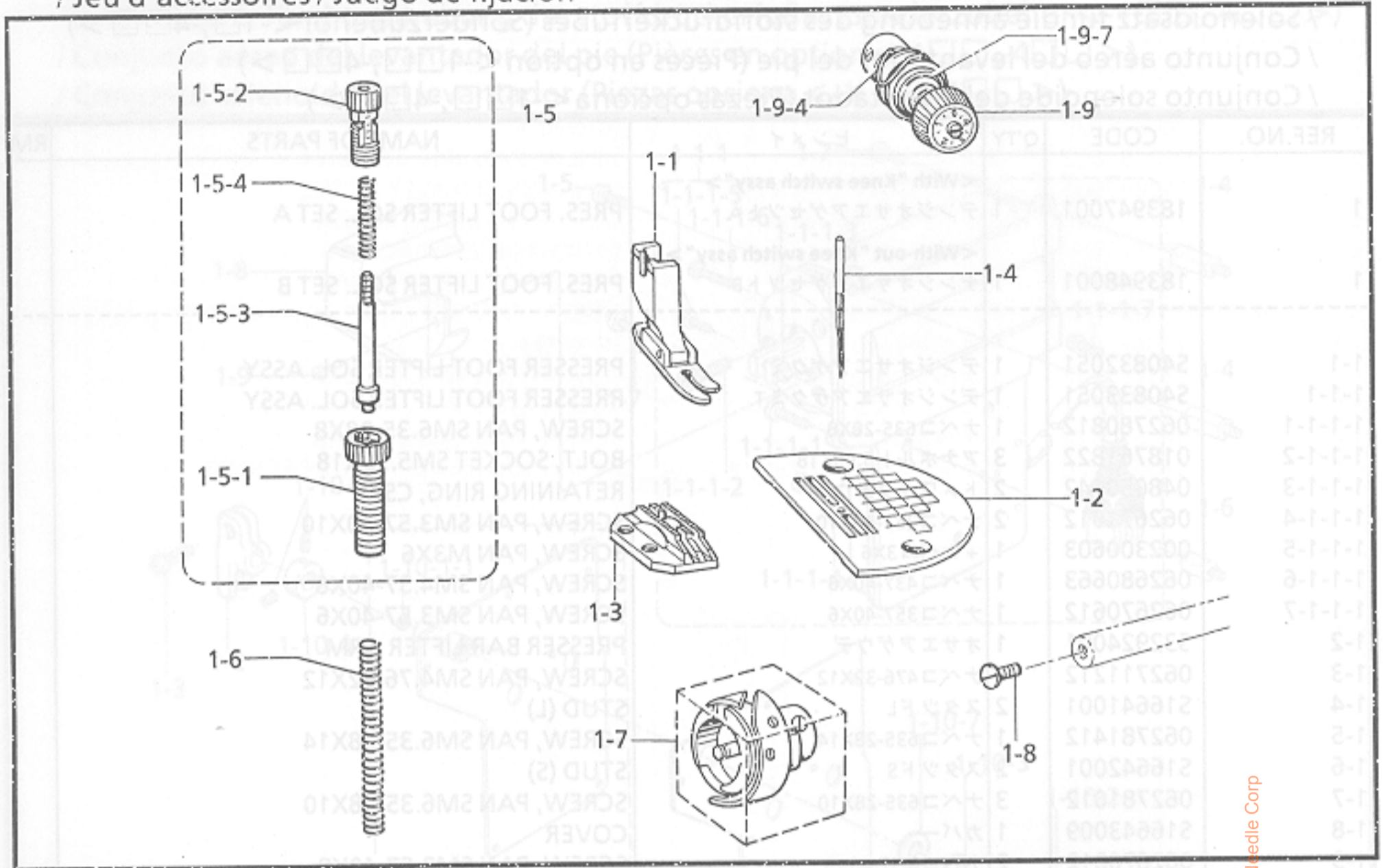

877-201-940

T. 逆転スイッチ関係 (-4□□,-9□□) / Quick reverse switch mechanism (-4□□,-9□□) / Umkehrschalter (-4□□,-9□□) / Mécanisme de interrupteur de marche arrière rapide (-4□□,-9□□) / Mecanismo del conmutador de inversión rápida (-4□□,-9□□)

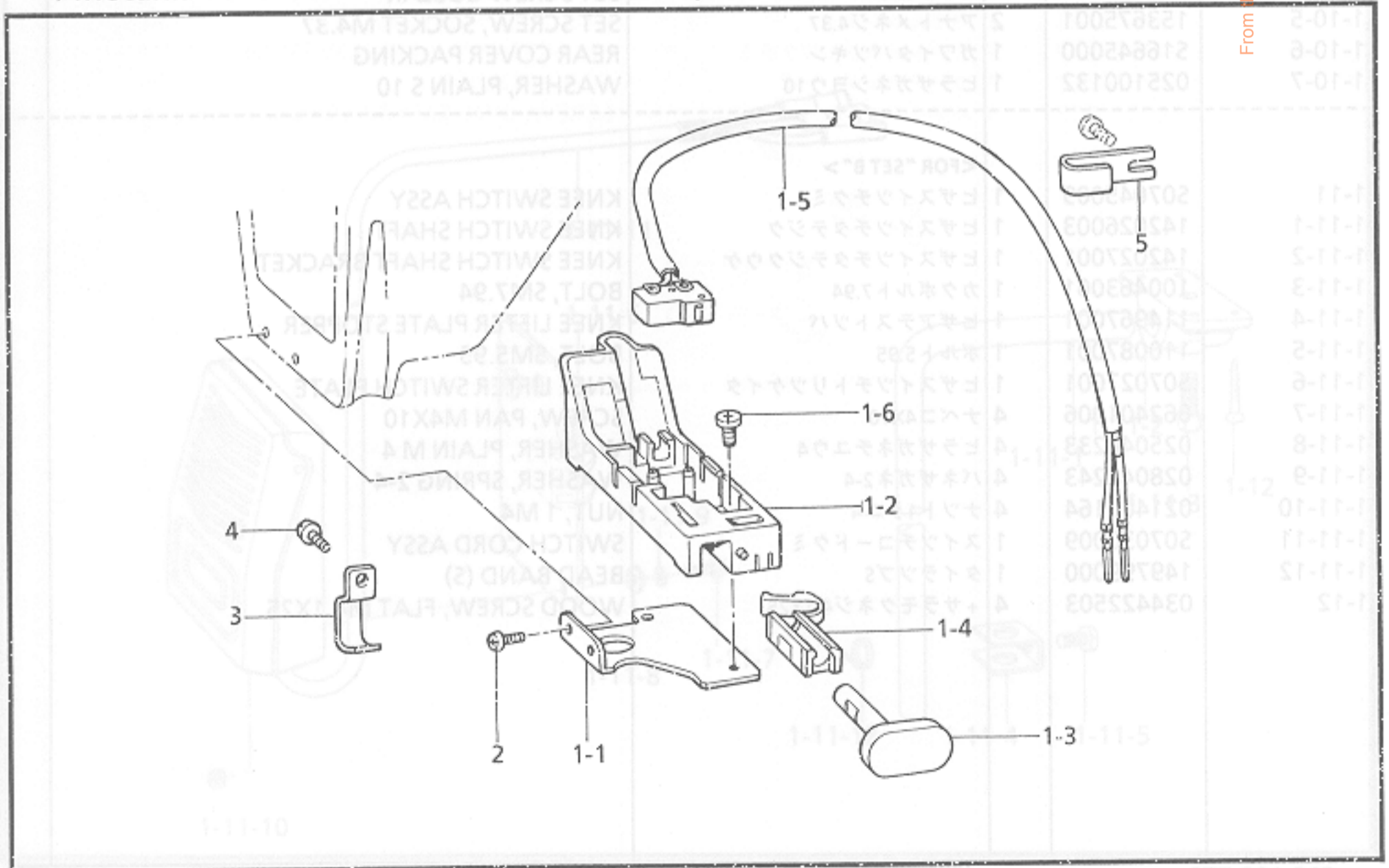

877-201-508

From the library of: Diamond Needle Corp

S. オプション部品関係 (新素材用) / Attachment set (For "Shin-gosen") / Anbausatz
/ Jeu d'accessoires / Juego de fijación

REF.NO.	CODE	Q'TY	ヒンメイ	NAME OF PARTS	RM
1	183911001	1	シンゴウセンパーツセット	PARTS SET FOR NEW SYNTHETIC FABRIC	
1-1	S35775310	1	ハリDBX1NS#10クミ	NEEDLE ASSY (DBX1 NS#10) <With scale>	
1-2	S35776101	1	ハリイタAB14M	NEEDLE PLATE AB14M <Needle hole "1.4">	
1-3	S02748001	1	オクリバAB	FEED DOG (AB) <Pitch"0.8">	
1-4	S35777001	1	オサエクミ	PRESSER FOOT ASSY	
1-5	S35779001	1	オサエチヨウセツネジクミ	PRESSER REGULATING SCREW ASSY	
1-5-1	S35780001	1	オサエチヨウセツネジ	PRESSER REGULATING SCREW	
1-5-2	S35781001	1	オサエアツチヨウセツネジ	PRESSER BAR PRESSURE REGULATING SCREW	
1-5-3	S35782001	1	オサエアツヒヨウジゲージ	PRESSER BAR PRESSURE GAUGE	
1-5-4	S35783001	1	オサエチヨウセツバネ	PRESSER REGULATING SPRING	
1-6	147514001	1	オサエバネ	PRESSER SPRING <Low tension type>	
1-7	S35784901	1	コウソクカマRPハコクミ	ROTARY HOOK BOX ASSY (RP)	
1-8	S35787001	1	オイルアナフタネジ	CAP SCREW <Lubrication hole-less>	
1-9	S35788001	1	イトチヨウシボウダイクミ	UPPER TENSION REGULATOR ASSY	
1-9-4	100399001	1	イトトリバネ	SPRING <Low tension type>	
1-9-7	115188001	1	シユイトチヨウシバネ	TENSION SPRING <Low tension type>	

T. 逆転スイッチ関係 (-4□□,-9□□) / Quick reverse switch mechanism (-4□□,-9□□)
/ Umkehrschalter (-4□□,-9□□)
/ Mécanisme de interrupteur de marche arrière rapide (-4□□,-9□□)
/ Mecanismo del conmutador de inversión rápida (-4□□,-9□□)

REF.NO.	CODE	Q'TY	ヒンメイ	NAME OF PARTS	RM
1	S32901021	1	Rアクチュエータークミ	REVERSE ACTUATOR ASSY	
1-1	S32902001	1	Rスイッチササエ	REVERSE SWITCH SUPPORT	
1-2	S32903000	1	Rスイッチダイ	REVERSE SWITCH BRACKET	
1-3	S32904020	1	アクチュエーター	ACTUATOR	
1-4	S32905000	1	Rスイッチバネ	SPRING, REVERSE SWITCH	
1-5	S32906000	1	Rスイッチクミ	REVERSE SWITCH ASSY	
1-6	060300606	1	バインド3X6	SCREW, BIND M3X6	
2	062670612	2	ナベコ357-40X6	SCREW, PAN SM3.57-40X6	
3	S02702001	2	コードオサエU2	CORD HOLDER (U2)	
4	062670612	2	ナベコ357-40X6	SCREW, PAN SM3.57-40X6	
5	S02704001	1	コードオサエ	CORD HOLDER	
47-1	S15172129	1	ベルトカバー	BELT COVER	
47-1-1	S15164021	1	メス	KNIFE	
47-1-2	062680512	1	ナベコ437-40X5	SCREW, PAN SM4.37-40X5	
47-2	S02705022	2	アルモクネジ5.5X20	WOOD SCREW, ROUND M5.5X20	
47-3	S02705032	2	ヒラザガネシヨウ5.56	WASHER, FLAT M5.56	
47-4	S11700002	1	ベルトカバーDフタ5	BELT COVER (D) LID (S)	
47-5	S14428025	1	ベルトカバーD	BELT COVER (D)	
47-6	S35761001	1	ベルトカバーUC	BELT COVER, UC	
51	S35722021	1	オイルタンク	OIL TANK	
52	S35723021	1	トウブカバー	HEAD COVER	

From the library of Diamond Needle Corp

877-201-940

877-201-508

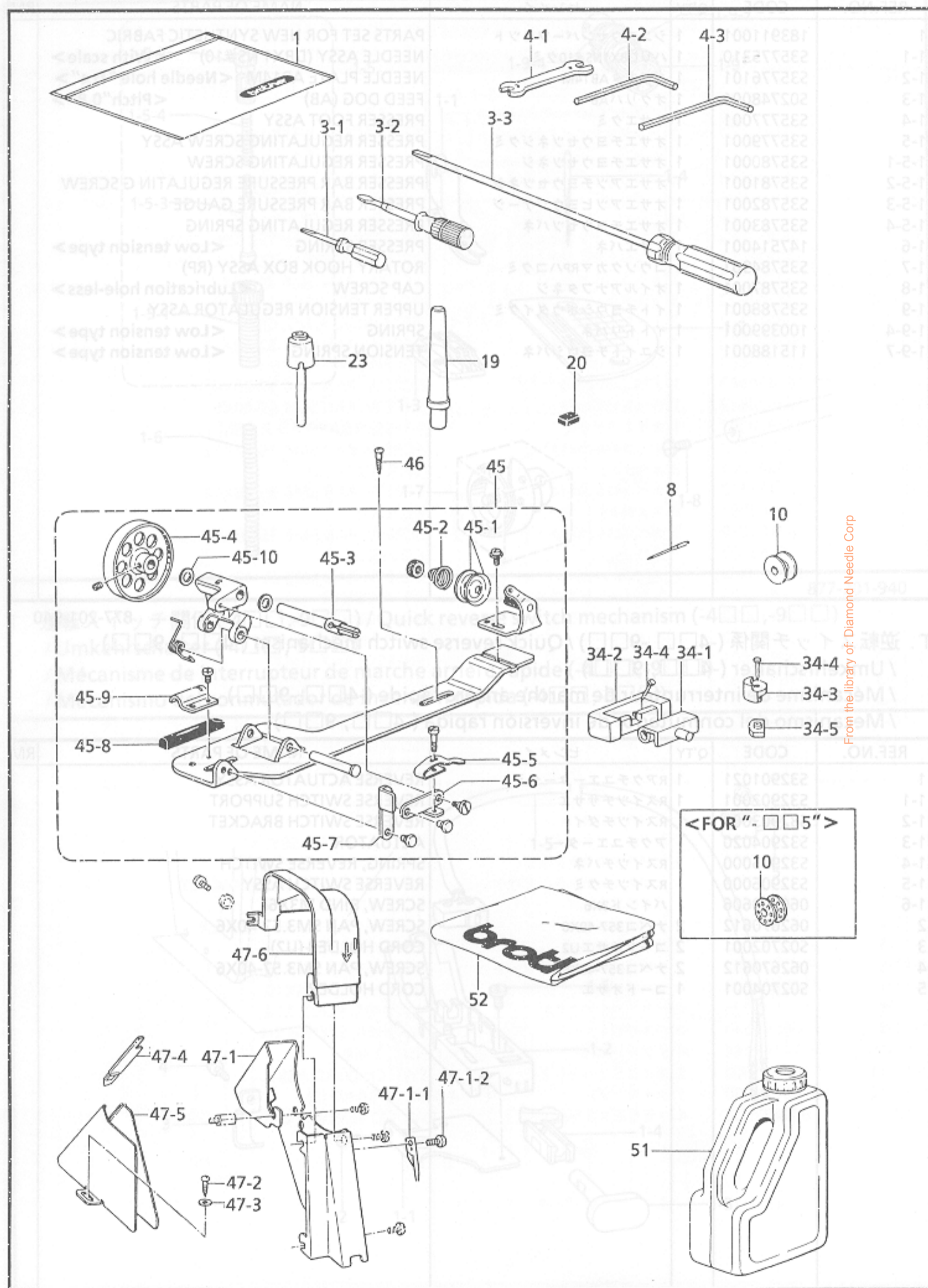

From the library of: Diamond Needle Corp

REF.NO.	CODE	Q'TY	ヒンメイ	NAME OF PARTS	RM
1-1	S35730021	1	フゾクヒンポリフクロ	ACCESSORY BAG	
3-1	142443021	1	ネジマワシ1.9X52	SCREW DRIVER 1.9X52	
3-2	118837021	1	ネジマワシ3.4X70	SCREW DRIVER 3.4X70	
3-3	S17774021	1	ネジマワシ4.7X250	SCREW DRIVER 4.7X250	
4-1	100887021	1	スパナ8X9	WRENCH 8X9	
4-2	146049001	1	6カクボウスパナ2	HEXAGONAL WRENCH 2	
4-3	142721001	1	6カクボウスパナ3	HEXAGONAL WRENCH, 3	
8	100265031	4	<FOR "-□□1"> ミシンハリDBX1	NEEDLE DBX1 (#11)	
8	107415011	4	ミシンハリDPX5	NEEDLE DPX5 (#11)	
8	100265031	4	<FOR "-□□3"> ミシンハリDBX1	NEEDLE DBX1 (#11)	
8	100265034	4	ミシンハリDBX1	NEEDLE DBX1 (#14)	
8	107415014	4	ミシンハリDPX5	NEEDLE DPX5 (#14)	
10	146290001	3	<FOR "-□□1,-□□3"> ボビン	BOBBIN	
8	100265042	4	<FOR "-□□5"> ミシンハリDBX1	NEEDLE DBX1 (#22)	
10	117132001	3	ボビン	BOBBIN	
19	S06055009	1	<FOR "-1□□,-4□□"> マクラS	HEAD REST (S)	
20	112525020	1	シユウジンマグネット	MAGNET	
23	S09634020	1	ヒザアゲオシボウ	KNEE LIFTER COMPLYING BAR	
34	S40014021	1	ラバーヒンジクミ	RUBBER HINGE ASSY	
34-1	143882021	2	トウブヒンジ	HEAD HINGE	
34-2	143910029	2	トウブヒンジウケゴム	RUBBER CUSHION	
34-3	S01302029	4	トウブシキゴム	HEAD CUSHION	
34-4	109714020	8	クギ	NAIL	
34-5	S01303000	4	オイルパンクツシヨン	OIL PAN CUSHION	
45	S14420020	1	イトマキクミ	BOBBIN WINDER ASSY	
45-1	145446003	2	イトチヨウシサラ	TENSION DISC	
45-2	100401001	1	イトチヨウシバネ	TENSION SPRING	
45-3	S15133001	1	イトマキジク	BOBBIN WINDER SHAFT	
45-4	S14424001	1	イトマキクルマ	BOBBIN WINDER WHEEL	
45-5	100656001	1	ボビンオサエ	BOBBIN PRESSER	
45-6	100658001	1	ボビンオサエウデ	BOBBIN PRESSER ARM	
45-7	S14426002	1	ボビンオサエダイ	BOBBIN PRESSER BRACKET	
45-8	100662001	1	イトマキクルマカイテンドメ	BOBBIN WINDER WHEEL STOPPER	
45-9	100664001	1	カイテンドメオサエ	WHEEL STOPPER HOLDER	
45-10	142711001	2	ファイバーワツシヤ	WASHER, VFS 6.5	
46	100666022	2	マルモクネジ5.5X20	WOOD SCREW, ROUND M5.5X20	
47	183658229	1	ベルトカバークミA	BELT COVER ASSY (A)	
47-1	S15172129	1	ベルトカバー	BELT COVER	
47-1-1	S15164021	1	メス	KNIFE	
47-1-2	062680512	1	ナベコ437-40X5	SCREW, PAN SM4.37-40X5	
47-2	100666022	2	マルモクネジ5.5X20	WOOD SCREW, ROUND M5.5X20	
47-3	025750132	2	ヒラザガネシヨウ5.56	WASHER, PLAIN S 5.56	
47-4	S37264021	1	ベルトカバーDフタS	BELT COVER (D) LID (S)	
47-5	S14428029	1	ベルトカバーD	BELT COVER (D)	
47-6	S37161021	1	ベルトカバーUC	BELT COVER, UC	
51	S35822021	1	オイルタンク	OIL TANK	
52	S35732021	1	トウブカバー	HEAD COVER	

From the library of: Diamond Needle Corp

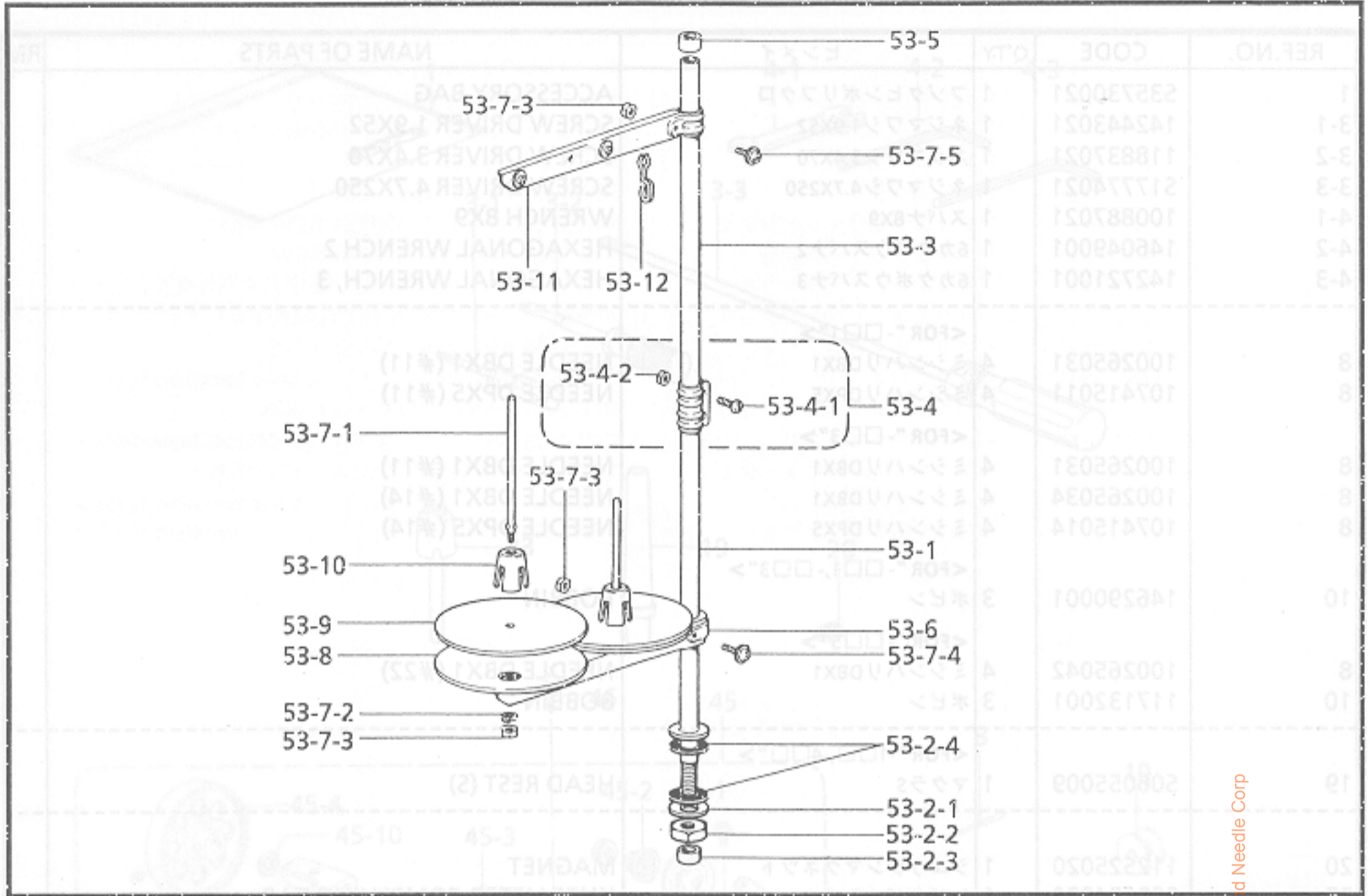

877-201-910

Wa . 警告ラベル / Warning labels / Warnschilder / Etiquettes d'avertissement / Etiquetas de advertencia

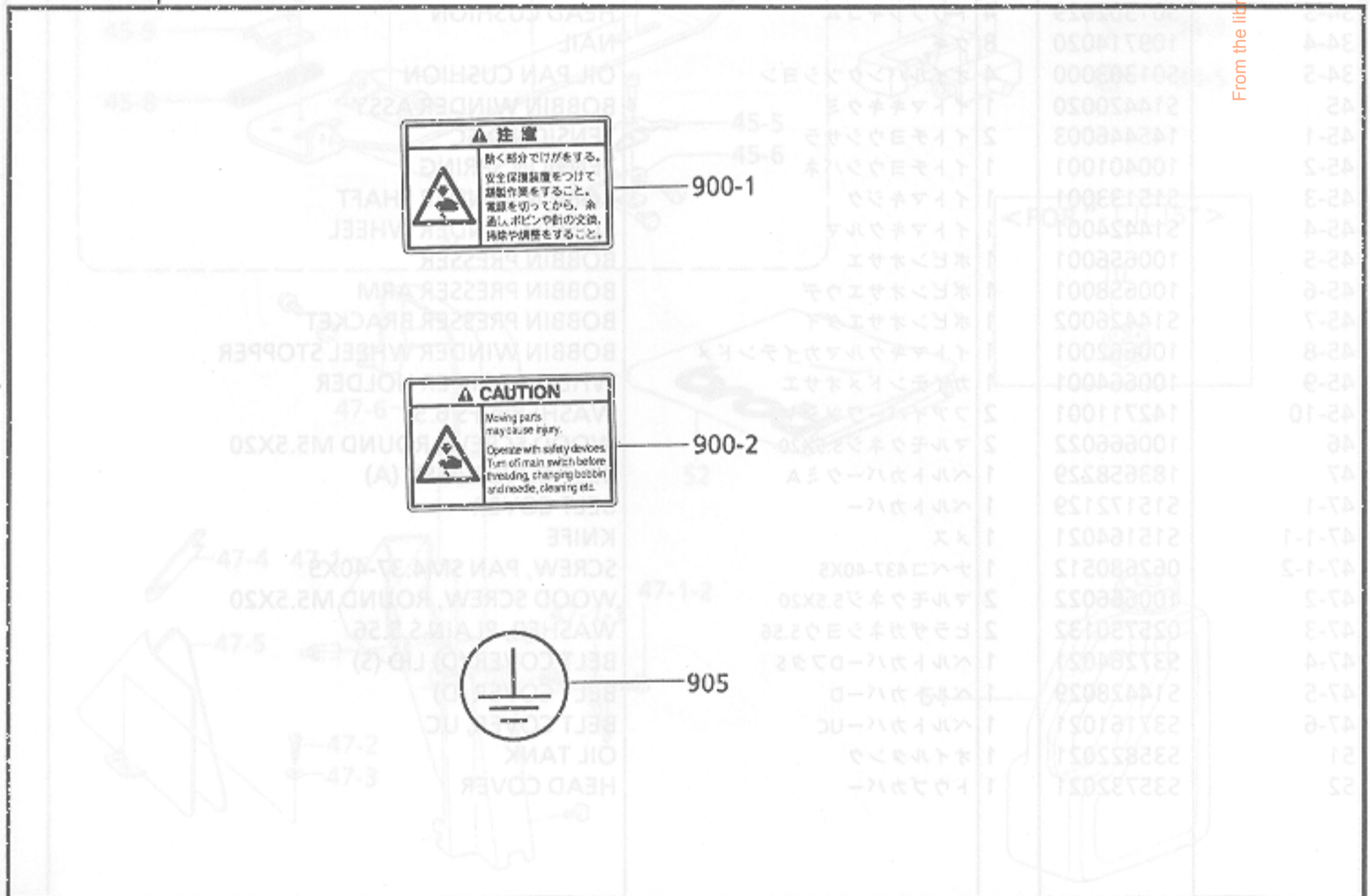

From the library of: Diamond Needle Corp

Z2. 付属品関係 / Accessories / Zubehör / Accessoires / Accesorios

REF.NO.	CODE	Q'TY	ヒンメイ	NAME OF PARTS	RM
53	S35829021	1	イトタテダイクミ2DR	COTTON STAND ASSY 2DR	
53-1	S36064021	1	コラムパイプD	COLUMN PIPE (D)	
53-2	S02777021	1	パイプDネジセットB	PIPE (D) SCREW SET	
53-2-1	150206022	1	ヒラザガネ16	WASHER, PLAIN 16	
53-2-2	S36062021	1	6カクナツトM16	NUT, M16	
53-2-3	S35635020	1	コラムキャップ	COLUMN CAP	
53-2-4	S01005020	2	イトタテゴム	RUBBER WASHER	
53-3	150172023	1	コラムパイプ	COLUMN PIPE	
53-4	S35828021	1	コラムジョイントクミ	COLUMN JOINT ASSY	
53-4-1	S35826021	2	ナベコ5X14	SCREW, PAN M5X14	
53-4-2	S35827021	2	1シユナツト5	NUT, 1 M5	
53-5	S35635020	1	コラムキャップ	COLUMN CAP	
53-6	S02778022	1	スプールホルダー2	SPOOL HOLDER 2	
53-7	S35833021	1	スプールネジセット2	SPOOL SCREW SET 2	
53-7-1	150179022	2	スプールジクB	SPOOL SHAFT (B)	
53-7-2	S35830021	2	バネザガネ2-5	WASHER, SPRING 2-5	
53-7-3	S35827021	4	1シユナツト5	NUT, 1 M5	
53-7-4	S35831021	1	+ナベザクミ5X30A	SCREW, PAN (P WASHER) M5X30A	
53-7-5	S35832021	1	+ナベザクミ5X14A	SCREW, PAN (P WASHER) M5X14A	
53-8	150180021	2	ウケザラ	SPOOL STAND BASE	
53-9	150182020	2	スプールのマット	SPOOL MAT	
53-10	126863021	2	スプールのクッション	SPOOL CUSHION	
53-11	S02786022	1	スレツドハンガークミ2	THREAD HANGER ASSY, 2	
53-12	S02747121	1	イトカケバネ	SPRING	

877-201-910

Wa. 警告ラベル / Warning labels / Warnschilder / Etiquettes d'avertissement / Etiquetas de advertencia

REF.NO.	CODE	Q'TY	ヒンメイ	NAME OF PARTS	RM
900-1	S38350001	1	ソウサチユウイラベル.ワ	LABEL, OPERATION JAP.	
900-2	S38349001	1	ソウサチユウイラベル.エイ	LABEL, OPERATION ENG.	
905	S37060001	1	アースマーク	LABEL, GROUNDING	

877-201-050

Sp. 仕様別部品一覧表 / DIFFERENT PARTS LIST / ZUBEHÖRLISTE / LISTE DES PIÈCES ACCESSOIRES / LISTA DE PIEZAS ACCESORIAS

REF.NO.	ヒンメイ / NAME OF PARTS	仕様 / Specification		
		- □□1 薄物用 / For Thin Materials	- □□3 中厚物用 / For Medium Thick Materials	- □□5 厚物用 / For Thick Materials
B-22	ハリイタ / NEEDLE PLATE	S03884321	←	111508001
		111859321	←	150792021
B-17	ハリボウ / NEEDLE BAR	S14811021	←	S02811001
		S14815021	←	-
B-18	ミシンハリ / NEEDLE	100265031 DBX1 (#11)	←	100265042 DBX1 (#22)
		107415011 DPX5 (#11)	100265034 DBX1 (#14)	-
		-	107415014 DPX5 (#14)	-
C-5	オサエバネ / PRESSER SPRING	147514001	141728001	←
		-	S13561101	-
C-7	オサエクミ / PRESSER FOOT ASSY	S36902021	←	S36903001
		-	S36905001	S36904021
D-65	オクリバ / FEED DOG	S03885001	111860101	S02742001
		-	S02742001	150793001
G-16	コウソクカマ / ROTARY HOOK ASSY	S06106001	S02603101	148846001
G-18	ボビン / BOBBIN	146290001	←	117132001

From the library of: Diamond Needle Corp



Ga 1. ゲージ部品一覧表 (薄・中厚物用3枚歯) / GAUGE PARTS LIST (Thin·Medium-thick materials / 3ROW)
 / LEHRENLISTE / LISTE DES PIÈCES D'ECARTEMENT / LISTA DE PIEZAS DE CALIBRADORES

3枚歯 / 3ROW

877-201-940

仕様 Specification	針板 Needle plate		送り歯 Feed dog			押工組 Presser foot assy			
	Mark		φ	R	T	P	H		
薄・中厚物用 Thin·Medium- thick materials	B12	153147-001	1.2	0.2	2.1	146231-001	1.15	6	S36902-021
	B14	146233-001	1.4	0.2	2.1				153037-201
	NB14M	S29649-001	1.4	0.2	2.1				S36905-001
	NB16M	S29646-001	1.6	0.2	2.1				113280-101
	B14	146050-001	1.4	0.2	2.8	S07649-001	1.15	6.7	S38187-001
	B14	147238-001	1.4	1	2.8				140957-101
	B16	153190-001	1.6	0.2	2.8	S02742001	1.6	6.7	S01904-001
	B16	147239-001	1.6	1	2.8				

☆ ネジ穴中心から送り歯の先端までの距離は、送り歯の中心から送り歯の先端までの距離から送り歯の幅を引いた長さで、送り歯の幅は送り歯の幅寸法表を参照してください。
 ☆ If a feed dog measuring 1.5mm from the center to the tip is used, the distance from the center of the feed bar to the tip of the feed dog is 0.7mm to the left.
 ☆ Falls ein Transporteur mit einem Durchmesser von 1,5 mm an der Schnebnähe des Schnebnähe verwendet wird, wird die Distanz vom Transporteurstang zum Ende des Transporteurstanges um die Breite des Transporteurstanges verkürzt.
 ☆ Si on utilise une grande dent de 1,5 mm de diamètre au centre de la barre d'entraînement, la distance entre le trou de vis et le centre de la dent, c'est-à-dire la manivelle de la barre de la dent, est de 0,7 mm à gauche.
 ☆ Si se utiliza un alimentador que mide 1,5 mm de diámetro en el centro del eje de tornillo y centro de la punta de la dent, o sea la manivela de la barra del alimentador y la manivela de la punta de la dent, es de 0,7 mm a la izquierda.

3枚歯 / 3ROW

877-201-940

仕様 Specification	針板 Needle plate			送り歯 Feed dog		押工組 Presser foot assy			
	Mark		ϕ	R	T	P	H		
中厚物用 Medium-thick materials	B18	145971-001	1.8	0.2	2.8	S07649-001	1.15	6.7	S36902-021
	B18M	S29645-001	1.8	0.2	2.8	S02742-001	1.6	6.7	153037-201
	B18	100266-001	1.8	1	2.8			S36905-001	
	B18	146232-001	1.8	0.2	2.1	146231-001	1.15	6	1132801-101
	H18	141096-001	1.8	1	2.8	117442-001	1.15	6.7	140957-101
	B20	S11222-001	2	0.2	2.8	S07649-001	1.15	6.7	
					S02742-001	1.6	6.7		

From the library of: Diamond Needle Corp

3枚歯 / 3ROW

877-201-940

仕様 Specification	針板 Needle plate			送り歯 Feed dog		押工組 Presser foot assy			
	Mark		ϕ	R	T	P	H		
厚物用 Thick materials	B22	100267-001	2.2	1	2.8	S02743-001	1.6	6.7	S36904-021
	B26	111241-001	2.6	1	2.8			145157-101	
	B26	147245-001	2.6	1	2.8			S36905-001	
	C26	111508-001	2.6	1	2.8	154742-001	1.6	6.8	113280-101
	C26	147322-101	2.6	1	2.8	S02743-001	2.1	6.7	
	C26M	S29644-001	2.6	1	2.8				

- ☆ ネジ穴中心から歯部中心まで11.9mmの送り歯を使用する場合、水平送り台腕と上下送り台腕を0.7mm左側へ移動させて下さい。
- ☆ If a feed dog measuring 11.9mm from the screw hole center to tooth center is be used, shift the feed bar crank and feed lifting crank 0.7mm to the left.
- ☆ Falls ein Transporteur mit der Abmessung von 11.9mm von der Schraubenlochmitte bis zur Zahnmitte verwendet wird, muß der Tranporteurstangenarm und der Arm zum 0.7mm nach links verschoben werden.
- ☆ Si on utilise une griffe d'entraînement mesurant 11.9mm entre le centre de trou de vis et le centre des dents, déplacer la manivelle de la barre d'entraînement et la manivelle de levée d'entraînement de 0.7mm vers la gauche.
- ☆ Si se utiliza un alimentador que mide 11.9mm, desde el centro del orificio de tornillo y centro de diente, desviar la manivela de la barra del alimentador y la manivela del levantador de alimentación 0.7mm a la izquierda.

4枚歯 / 4ROW

877-201-940

仕様 Specification	針板 Needle plate			送り歯 Feed dog		押工組 Presser foot assy			
	Mark		φ	R	T	P	H		
薄・中厚物用 Thin-Medium-thick materials	E12N1	S03882-201	1.2	1	2.1	S03885-001	0.9	6	S36902-021
	E14N1	S03883-201	1.4	1	2.1				153037-201
	E14N1	159859-201	1.4	1	2.1				S36905-001
	E12	S01107-101	1.2	1	2.1	S13684-001	1.6	6.7	113280-101
	AB14N1	S02999-201	1.4	0.2	2.1	S02748-001	0.9	6	140957-101
	AB16N1	S03000-201	1.6	0.2	2.1	S02744-001	1.15	6	S38189-001
AB16	156115-001	1.6	0.2	2.8	S13684-001	1.6	6.7	147531-101	
新素材用 For "shin-gosen"	AB14M1	S35776-101	1.4	0.2	2.1	S02748-001	0.9	6	S35777-001 or S38190-001

From the library of: Diamond Needle Corp

Ga 5. ゲージ部品一覧表 (薄・中厚物用4枚歯) / GAUGE PARTS LIST (Thin-Medium-thick materials / 4ROW)
 / LEHRENLISTE / LISTE DES PIECES D' ECARTEMENT / LISTA DE PIEZAS DE CALIBRADORES

4枚歯 / 4ROW

877-201-940

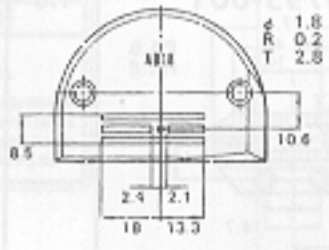
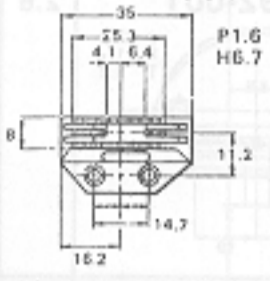
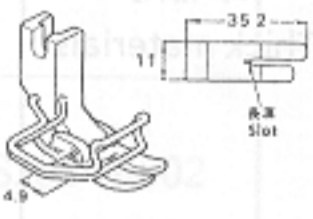
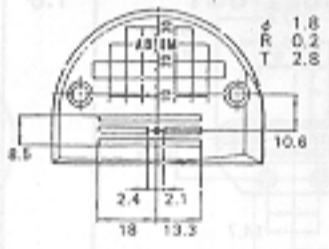
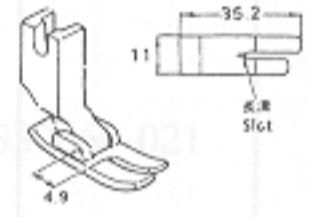
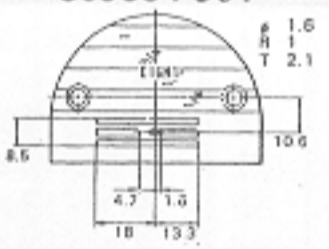
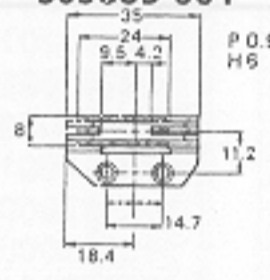
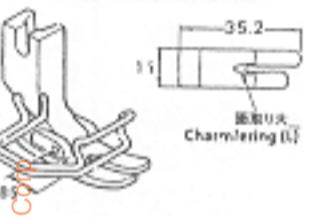
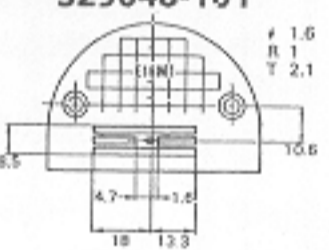
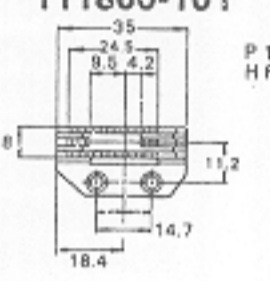
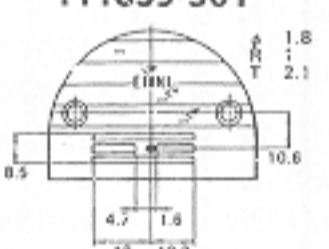
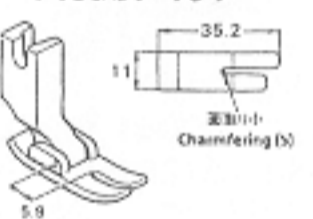
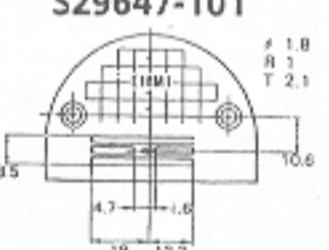
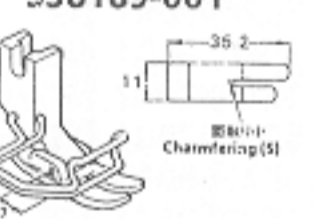
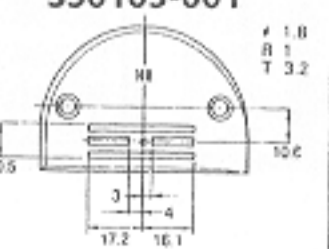
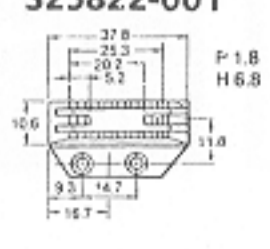
仕様 Specification	針板 Needle plate		送り歯 Feed dog			押工組 Presser foot assy			
	Mark		φ	R	T	P	H		
薄・中厚物用 Thin-Medium-thick materials	AB18	156116-001 	1.8	0.2	2.8	S13684-001 	1.6	6.7	S36902-021 
	AB18M	S31910-001 	1.8	0.2	2.8				S153037-201 
	E16N1	S03884-301 	1.6	1	2.1	S03885-001 	0.9	6	S36905-001 
	E16M1	S29648-101 	1.6	1	2.1				111860-101 
中厚物用 Medium-thick materials	E18N1	111859-301 	1.8	1	2.1				140957-101 
	E18M1	S29647-101 	1.8	1	2.1				S38189-001 
	H18	S30103-001 	1.8	1	3.2				S25822-001 

From the library of Diamond Needle Corp.

Ga 6. ゲージ部品一覧表 (厚物用4枚歯) / GAUGE PARTS LIST (Thick materials / 4ROW)
 / LEHRENLISTE / LISTE DES PIÈCES D'ECARTEMENT / LISTA DE PIEZAS DE CALIBRADORES



4枚歯 / 4ROW

877-201-940

仕様 Specification	針板 Needle plate		送り歯 Feed dog			押工組 Presser foot assy			
	Mark		φ	R	T	P	H		
厚物用 Thick materials	H26	150792-001 	2.6	1	3.2	150793-001 	1.8	6.8	S36903-001
	H26	S25821-001 	2.6	1	3.2	S25822-001 	1.8	6.8	150789-101

From the library of: Diamond Needle Corp

警告ラベル / Warning labels / Warnschilder / Etiquettes d'avertissement
 / Etiquetas de advertencia

	品名 / Name of parts	Size(mm)	Code
	Label, operation Eng.	40 × 64	S38349-021
		52 × 84	S38349-002
	アースマーク Mark, grounding	φ12	S37060-021

From the library of: Diamond Needle Corp

索引 / INDEX / VERZEICHNIS
/ INDEX / INDICE

CODE	REF.NO.	Page	CODE	REF.NO.	Page	CODE	REF.NO.	Page
S00337001	K - 1	24	S02742001	D - 65	12	S11222001	Ga2 - B20	43
S00879021	C - 35	8		Sp - D-65	41	S11308001	Q - 4	32
S00909021	B - 1-2	4		Ga1 - B16	42	S11589000	R - 1-10-1-1	34
S01005020	Z2 - 53-2-4	40		Ga2 - B20	43	S11683000	K - 52	26
S01107101	Ga4 - E12	45		Ga2 - B18M	43	S11684000	K - 51-1	26
S01302029	Z1 - 34-3	38	S02743001	Ga3 - B22	44	S12441001	J - 14-8	22
S01303000	Z1 - 34-5	38		Ga3 - C26	44	S13163001	B - 11-1	4
S01998021	C - 13	8	S02744001	Ga4 - AB16N1	45	S13385001	C - 8	8
S02524001	B - 6	4	S02745001	K - 49	24	S13561101	C - 5	8
S02538029	B - 25	4	S02747121	Z2 - 53-12	40		Sp - C-5	41
S02546202	C - 14	8	S02748001	S - 1-3	36	S13684001	Ga4 - E12	45
S02548001	C - 24	8		Ga4 - AB14M1	45		Ga4 - AB16	45
S02552021	D - 1	10		Ga4 - AB14N1	45		Ga5 - AB18	46
S02554001	D - 2	10	S02777021	Z2 - 53-2	40	S14420020	Z1 - 45	38
S02556001	D - 28	10	S02778022	Z2 - 53-6	40	S14424001	Z1 - 45-4	38
S02557000	D - 33	10	S02786022	Z2 - 53-11	40	S14426002	Z1 - 45-7	38
S02558201	D - 37	10	S02811001	B - 17	6	S14428029	Z1 - 47-5	38
S02562001	D - 45	12		Sp - B-17	41	S14811021	B - 17	4
S02563001	D - 46	12	S02815009	K - 36	24		Sp - B-17	41
S02568121	D - 53	12	S02999201	Ga4 - AB14N1	45	S14814001	B - 21	4
S02569121	D - 61	12	S03000201	Ga4 - AB16N1	45	S14815021	B - 17	4
S02574121	D - 67	14	S03245001	G - 17	18		Sp - B-17	41
S02575000	D - 73	14	S03246001	G - 17-4	18	S15133001	Z1 - 45-3	38
S02576021	D - 78	14	S03254001	J - 14-1	22	S15164021	Z1 - 47-1-1	38
S02578101	D - 81	14	S03327000	P - 6	32	S15172129	Z1 - 47-1	38
S02592009	F - 1-2	16	S03328000	K - 48-1	24	S15589000	N - 31	30
S02597009	L - 1	28	S03670001	M - 11	28	S15889021	H - 1-6	20
S02600000	L - 2	28	S03677001	N - 30	30	S16615002	R - 1-10-	34
S02602021	G - 14	18	S03815001	K - 47	26	S16641001	F - 4	16
S02603101	G - 16	18	S03818101	D - 37	10		R - 1-4	34
	Sp - G-16	41	S03882201	Ga4 - E12N1	45	S16642001	F - 6	16
S02606000	H - 3	20	S03883201	Ga4 - E14N1	45		R - 1-6	34
S02608021	H - 16-1	20	S03884301	Ga5 - E16N1	46	S16643009	F - 8	16
S02609100	H - 23	20	S03884321	B - 22	4		R - 1-8	34
S02611001	J - 1-1	22		Sp - B-22	41	S16644102	A - 27	2
S02612001	J - 1-2	22	S03885001	D - 65	12		R - 1-10	34
S02614124	J - 11	22		Sp - D-65	41	S16645000	R - 1-10-6	34
S02617001	A - 34-4	2		Ga4 - E12N1	45	S17774021	Z1 - 3-3	38
S02620001	J - 14-4	22		Ga5 - E16N1	46	S19056001	J - 10	22
S02637001	K - 4	24	S04228001	D - 84	14	S21514121	D - 50-3	12
S02643001	K - 6	24	S04632001	J - 14-7	22	S23836001	K - 40	24
S02645001	K - 13	24	S05898021	D - 5	10	S25279001	N - 20	30
S02647001	K - 22	24	S06055009	Z1 - 19	38	S25349021	D - 62	12
S02648001	K - 23	24	S06106001	G - 16	18	S25437000	K - 19	24
S02652001	K - 39	24		Sp - G-16	41	S25449101	N - 5	30
S02655002	K - 42	24	S06325021	B - 1-2	4	S25452001	N - 17	30
S02657001	K - 45	24	S06684021	H - 16	20	S25454001	N - 19	30
S02658000	M - 1	28	S06999021	D - 50-1	12	S25456001	N - 26	30
S02659101	M - 2	28	S07027001	R - 1-11-6	34	S25821001	Ga6 - H26	47
S02660101	M - 8	28	S07030009	R - 1-11-11	34	S25822001	Ga5 - H18	46
S02664001	N - 1-2	30	S07045009	R - 1-11	34		Ga6 - H26	47
S02665000	N - 1-3	30	S07649001	Ga1 - B14	42	S28919021	C - 30	8
S02668000	N - 4	30		Ga2 - B18	43	S28926020	P - 14	32
S02672002	N - 16	30		Ga2 - B20	43	S28927020	H - 2	20
S02678001	N - 21	30	S07959001	D - 34	10	S28928020	A - 27-5	2
S02679002	N - 22	30		L - 3	28	S29644001	Ga3 - C26M	44
S02681001	N - 27	30	S07972001	J - 6	22	S29645001	Ga2 - B18M	43
S02682001	K - 48	24	S08003000	H - 34	20	S29646001	Ga1 - NB16M	42
S02684101	P - 1	32	S08004001	H - 35	20	S29647101	Ga5 - E18M1	46
S02685001	P - 2	32	S09621001	A - 25	2	S29648101	Ga5 - E16M1	46
S02687201	P - 7	32	S09634020	Z1 - 23	38	S29649001	Ga1 - NB14M	42
S02702001	T - 3	36	S09635021	H - 1-2	20	S30103001	Ga5 - H18	46
S02704001	T - 5	36	S11210000	K - 51	26	S31006001	C - 25	8

From the library of: Diamond Needle Corp

CODE	REF.NO.	Page
S31012001	C - 3	8
S31013001	C - 31	8
S31014020	D - 55	12
	D - 68	14
S31015021	D - 50	12
S31016001	D - 50-2	12
S31018021	D - 50	12
S31019001	D - 50-2	12
S31026020	G - 6	18
S31027020	G - 19	18
S31031001	J - 14	22
S31032001	J - 14-9	22
S31034001	J - 14	22
S31885001	E - 1-8	16
S31910001	Ga5- AB18M	46
S31952021	C - 28	8
S32348021	H - 20-1	20
S32349001	H - 24	20
S32901021	T - 1	36
S32902001	T - 1-1	36
S32903000	T - 1-2	36
S32904020	T - 1-3	36
S32905000	T - 1-4	36
S32906000	T - 1-5	36
S32920001	D - 38	10
S32922021	D - 39	10
S32923001	A - 27-1	2
	R - 1-10-2	34
S32924001	F - 2	16
	R - 1-2	34
S32925100	H - 5	20
S32926001	H - 36	20
S33608001	N - 1-1	30
S33609001	N - 10	30
S33610001	N - 14	30
S33611001	N - 32	30
S33612001	N - 3	30
S33613001	N - 33	30
S33689002	B - 26	4
S34112001	N - 1	30
S34290021	B - 11	4
S34295001	B - 11	4
S34448001	Q - 2	32
S34756021	E - 1-5	16
S35529020	A - 34-2	2
S35635020	Z2 - 53-2-3	40
	Z2 - 53-5	40
S35730021	Z1 - 1	38
S35732021	Z1 - 52	38
S35775310	S - 1-1	36
S35776101	S - 1-2	36
	Ga4- AB14M1	45
S35777001	S - 1-4	36
	Ga4- AB14M1	45
S35779001	S - 1-5	36
S35780001	S - 1-5-1	36
S35781001	S - 1-5-2	36
S35782001	S - 1-5-3	36
S35783001	S - 1-5-4	36
S35784901	S - 1-7	36
S35787001	S - 1-8	36
S35788001	S - 1-9	36
S35817021	B - 15	4

CODE	REF.NO.	Page
S35818021	D - 41	10
S35820021	E - 1-3	16
S35821021	E - 1	16
S35822021	Z1 - 51	38
S35826021	Z2 - 53-4-1	40
S35827021	Z2 - 53-4-2	40
	Z2 - 53-7-3	40
S35828021	Z2 - 53-4	40
S35829021	Z2 - 53	40
S35830021	D - 87	14
	Z2 - 53-7-2	40
S35831021	Z2 - 53-7-4	40
S35832021	Z2 - 53-7-5	40
S35833021	Z2 - 53-7	40
S36062021	Z2 - 53-2-2	40
S36064021	Z2 - 53-1	40
S36827021	A - 34	2
S36828021	A - 34-1	2
S36900020	C - 7-1	8
S36902001	Ga1- B12	42
	Ga2- B18	43
	Ga4- E12N1	45
	Ga5- AB18	46
S36902021	C - 7	8
	Sp - C-7	41
S36903001	C - 7	8
	Sp - C-7	41
	Ga5- H18	46
	Ga6- H26	47
S36904001	Ga3- B22	44
S36904021	C - 7	8
	Sp - C-7	41
S36905001	C - 7	8
	Sp - C-7	41
	Ga1- NB14M	42
	Ga2- B18	43
	Ga3- B26	44
	Ga4- E14N1	45
	Ga5- E16N1	46
S37060001	Wa - 905	40
S37161021	Z1 - 47-6	38
S37264021	Z1 - 47-4	38
S37333001	D - 83	14
S37812021	B - 1	4
S37813021	B - 1	4
S37814021	B - 1-1	4
S37815021	B - 2	4
S38187001	Ga1- B14	42
S38189001	Ga4- AB16N1	45
	Ga5- E18M1	46
S38190001	Ga4- AB14M1	45
S38349001	Wa - 900-2	40
S38350001	Wa - 900-1	40
S39560021	A - 6	2
S40014021	Z1 - 34	38
S40016001	H - 18	20
S40017000	H - 17	20
S40832051	F - 1	16
	R - 1-1	34
S40833051	F - 1-1	16
	R - 1-1-1	34
002300603	F - 1-1-5	16
	R - 1-1-1-5	34

CODE	REF.NO.	Page
013760610	B - 5	4
	G - 5	18
013761410	D - 1-1	10
	G - 7	18
013781012	B - 12	4
014680422	D - 32	10
	D - 36	10
	H - 16-2	20
014680622	D - 5-3	10
	D - 15	10
	D - 21	10
	G - 10	18
	J - 2	22
	K - 40-1	24
	Q - 3	32
014761030	D - 30	10
014770622	K - 29	24
014771022	B - 1-4	4
	K - 3	24
017681012	A - 28	2
018680822	N - 25	30
018761822	F - 1-1-2	16
	R - 1-1-1-2	34
021400164	R - 1-1-1-10	34
025040233	R - 1-1-1-8	34
025100132	A - 27-6	2
	R - 1-1-0-7	34
025750132	Z1 - 47-3	38
026040236	N - 13	30
028040243	R - 1-1-1-9	34
034422503	R - 1-2	34
048030342	N - 24	30
048040342	C - 17	8
	N - 18	30
048050142	F - 1-1-3	16
	R - 1-1-1-3	34
048060342	D - 20	10
	K - 35	24
048070342	D - 29	10
048080342	A - 27-2	2
	D - 42	10
	R - 1-10-3	34
048150142	D - 57	12
	D - 70	14
060300606	T - 1-6	36
060400516	N - 15	30
	N - 28	30
060670612	A - 34-5	2
	M - 7	28
	Q - 5	32
062300616	N - 6	30
	N - 8	30
	N - 9	30
062351216	C - 26	8
062400616	N - 12	30
062401006	R - 1-11-7	34
062630712	P - 8	32
062670412	D - 80	14
062670516	H - 27	20
062670612	A - 26	2
	F - 1-1-7	16
	F - 1-3	16
	H - 6	20

CODE	REF.NO.	Page
062670612	P - 13	32
	R - 1-1-1-7	34
	T - 2	36
	T - 4	36
062670712	D - 44	10
062670812	F - 9	16
	H - 20-5	20
	M - 5	28
	R - 1-9	34
062671012	A - 35	2
	F - 1-1-4	16
	R - 1-1-1-4	34
062671612	M - 9	28
062680512	Z1 - 47-1-2	38
062680663	F - 1-1-6	16
	K - 50	24
	R - 1-1-1-6	34
062680712	H - 22	20
	J - 8	22
	J - 12	22
	K - 8	24
062680812	A - 31	2
062681012	A - 7	2
	N - 11	30
062681212	D - 60	12
	G - 15	18
	K - 12	24
062681412	D - 71-1	14
062681612	P - 4	32
062711012	L - 4	28
	P - 11	32
062711212	D - 74	14
	F - 3	16
	R - 1-3	34
062711412	D - 13	10
	K - 20	24
062760812	A - 32	2
062780812	F - 1-1-1	16
	R - 1-1-1-1	34
062781012	F - 7	16
	R - 1-7	34
062781412	F - 5	16
	R - 1-5	34
081001670	H - 10	20
081004070	H - 31	20
081007070	H - 1-11	20
081014670	H - 4	20
100022004	H - 1-5	20
100032004	B - 23	4
100080003	D - 66	12
100251001	B - 7-1	4
	G - 1-1	18
	G - 1-2-1	18
	G - 2-1	18
	G - 2-2-1	18
100260001	B - 16	4
100265031	B - 18	4
	B - 18	4
	Sp - B-18	41
	Sp - B-18	41
	Z1 - 8	38
	Z1 - 8	38
100265034	B - 18	4

CODE	REF.NO.	Page
100265034	Sp - B-18	41
	Z1 - 8	38
100265036	B - 18	6
100265039	B - 18	6
100265042	B - 18	6
	Sp - B-18	41
	Z1 - 8	38
100266001	Ga2 - B18	43
100267001	Ga3 - B22	44
100328001	D - 52	12
100399001	S - 1-9-4	36
100400000	J - 4	22
100401001	Z1 - 45-2	38
100402004	J - 14-3	22
100463001	R - 1-11-3	34
100463021	E - 1-2	16
100511003	D - 82	14
100573001	J - 13	22
100645003	K - 7	24
	K - 11	24
	P - 3	32
100645023	A - 29	2
	A - 29	2
100656001	Z1 - 45-5	38
100658001	Z1 - 45-6	38
100662001	Z1 - 45-8	38
100664001	Z1 - 45-9	38
100666022	Z1 - 46	38
	Z1 - 47-2	38
100887021	Z1 - 4-1	38
101487000	H - 9	20
101706001	D - 58-1	12
	D - 72-1	14
	G - 13-1	18
102571003	K - 17	24
102630021	B - 20	4
102707021	C - 27	8
102843004	K - 5	24
103950003	J - 5	22
104449009	A - 8	2
	A - 34-3	2
104450109	A - 9	2
	A - 30	2
104451009	A - 14	2
104464001	B - 1-3	4
104520020	G - 11	18
104525001	J - 14-7	22
104564001	D - 43	10
104619022	E - 1-4	16
104689002	D - 76	14
104821009	A - 11	2
104829121	A - 2	2
104830121	A - 3	2
104832009	A - 10	2
104885121	H - 1-4	20
105234003	K - 28	24
107155001	H - 15	20
107415011	B - 18	4
	Sp - B-18	41
	Z1 - 8	38
107415014	B - 18	4
	Sp - B-18	41
	Z1 - 8	38

CODE	REF.NO.	Page
107415022	B - 18	6
108520009	A - 13	2
108549001	D - 50-4	12
108804001	H - 8	20
108808001	H - 33	20
108960002	D - 4	10
109173101	H - 11	20
109714020	Z1 - 34-4	38
109763022	C - 16	8
110087001	R - 1-11-5	34
110087021	E - 1-7	16
110161004	M - 3	28
110197001	A - 27-3	2
	R - 1-10-4	34
110201001	K - 41	24
110367001	B - 13	4
	K - 34	24
110735002	N - 23	30
111241001	Ga3 - B26	44
111466121	C - 1	8
111469101	J - 7	22
111508001	B - 22	6
	Sp - B-22	41
	Ga3 - C26	44
111859301	Ga5 - E18M1	46
111859321	B - 22	4
	Sp - B-22	41
111860101	D - 65	12
	Sp - D-65	41
	Ga5 - E16M	46
111863001	H - 32	20
111865009	H - 7	20
112467022	H - 20-8	20
112525020	Z1 - 20	38
113280101	Ga1 - NB16M	42
	Ga2 - B18	43
	Ga3 - C26	44
	Ga4 - E12	45
	Ga5 - E16M1	46
113280121	C - 7	8
113431002	P - 10	32
114294001	J - 14-10	22
114561021	B - 24-1	4
114967001	R - 1-11-4	34
114967021	E - 1-6	16
115188001	S - 1-9-7	36
116794001	H - 14	20
116922001	J - 14-2	22
117132001	G - 18	18
	Sp - G-18	41
	Z1 - 10	38
117242021	B - 14	4
117442001	Ga2 - H18	43
118672021	A - 4	2
118734021	D - 23	10
118735021	D - 24	10
118758021	D - 77	14
118761021	G - 9	18
118837021	Z1 - 3-2	38
120990001	D - 64	12
121007001	G - 12	18
122771002	B - 24-2	4
126863021	Z2 - 53-10	40

From the library of: Diamond Needle Corp

CODE	REF.NO.	Page
140004001	B - 11-3	4
	B - 11-3	4
140407001	C - 6	8
140518001	H - 1-10	20
140553102	B - 19	4
140647001	L - 5	28
	N - 7	30
	P - 12	32
140704021	A - 5	2
140726020	B - 4	4
140957101	Ga1- B14	42
	Ga2- H18	43
	Ga4- AB14N1	45
	Ga5- E18N1	46
141096001	Ga2- H18	43
141208021	C - 4	8
141728001	C - 5	8
	Sp - C-5	41
142026003	R - 1-11-1	34
142027001	R - 1-11-2	34
142274009	A - 12	2
142403001	C - 36	8
142443021	Z1 - 3-1	38
142708020	G - 4	18
142711001	Z1 - 45-10	38
142721001	Z1 - 4-3	38
142746022	D - 50-5	12
143548000	K - 51-2	26
143549000	K - 51-3	26
	L - 1-1	28
	N - 1-4	30
143882021	Z1 - 34-1	38
143910029	Z1 - 34-2	38
144458001	D - 11	10
144504001	J - 1-3	22
144869022	H - 20-2	20
144872121	H - 21	20
144874021	H - 20-4	20
144875021	H - 20-6	20
144876001	H - 20-7	20
144878001	H - 20-9	20
145157101	C - 7	8
	Ga3- B26	44
145446001	J - 14-5	22
145446003	Z1 - 45-1	38
145465001	B - 11-1	4
145472021	C - 2	8
145474101	C - 12	8
145475101	C - 15	8
145476021	C - 20	8
145478022	C - 21	8
145479022	C - 22	8
145480101	C - 23	8
145502021	D - 51	12
145516021	G - 3	18
145522001	J - 9	22
145534001	H - 13	20
145543001	H - 25	20
145547021	H - 26	20
145580021	C - 10	8
145600020	B - 11-2	4
145624000	B - 11-5	4
	B - 11-5	6

CODE	REF.NO.	Page
145737021	H - 28	20
145751001	H - 12	20
145971001	Ga2- B18	43
146020009	K - 44	26
146036121	H - 1-1	20
146039021	E - 1-1	16
146040001	H - 1-9	20
146049001	Z1 - 4-2	38
146050001	Ga1- B14	42
146196001	H - 29	20
146231001	Ga1- B12	42
	Ga2- B18	43
146232001	Ga2- B18	43
146233001	Ga1- B14	42
146253000	H - 30	20
	L - 6	28
146288001	N - 29	30
146290001	G - 18	18
	Sp - G-18	41
	Z1 - 10	38
146293001	H - 1-7	20
146327001	B - 1-5	4
146333001	B - 1-6	4
146367021	H - 1-3	20
147238001	Ga1- B14	42
147239001	Ga1- B16	42
147245001	Ga3- B26	44
147322101	Ga3- C26	44
147326021	B - 15	6
147504021	D - 40	10
147509021	D - 75	14
147514001	C - 5	8
	S - 1-6	36
	Sp - C-5	41
147531101	Ga4- AB16	45
	Ga5- E18M1	46
147557101	J - 3	22
147777000	B - 11-4	4
	B - 11-4	6
148537101	K - 14	24
148846001	G - 16	18
	Sp - G-16	41
148849021	H - 20-3	20
148901001	J - 13	22
149085001	D - 39	10
149578020	H - 1-8-1	20
149580321	H - 1-8	20
149799000	R - 1-11-12	34
150172023	Z2 - 53-3	40
150179022	Z2 - 53-7-1	40
150180021	Z2 - 53-8	40
150182020	Z2 - 53-9	40
150206022	Z2 - 53-2-1	40
150384121	C - 29	8
150789101	C - 7	8
	Ga5- H18	46
	Ga6- H26	47
150792001	Ga6- H26	47
150792021	B - 22	6
	Sp - B-22	41
150793001	D - 65	12
	Sp - D-65	41
	Ga6- H26	47

CODE	REF.NO.	Page
151308121	D - 31	10
	D - 35	10
151594001	B - 21	6
151604001	D - 25	10
	D - 78-1	14
151607001	K - 25	24
151987002	K - 16	24
153037201	C - 7	8
	Ga1- B14	42
	Ga2- B18M	43
	Ga4- E14N1	45
	Ga5- AB18M	46
153132000	D - 49	12
153147001	Ga1- B12	42
153190001	Ga1- B16	42
153484021	D - 86	14
153675001	A - 27-4	2
	R - 1-10-5	34
153969000	K - 46	24
153970001	K - 47	26
154552001	G - 8	18
154562001	J - 1-4	22
154567000	K - 2	24
154570001	K - 9	24
154571001	K - 10	24
154576003	K - 15	24
154577001	K - 18	24
154579001	K - 21	24
154581001	K - 24	24
154582001	K - 26	24
154590001	K - 27	24
154593201	K - 30	24
154594000	K - 31	24
154595001	K - 32	24
154596000	K - 33	24
154598001	K - 37	24
154599000	K - 38	24
154606001	M - 4	28
154607001	M - 6	28
154742-00	Ga3- C26	44
155347001	M - 10	28
155488000	B - 11-6	4
	B - 11-6	6
155559001	K - 43	24
156115001	Ga4- AB16	45
156116001	Ga5- AB18	46
156217009	A - 24	2
156243021	D - 56	12
	D - 69	14
156244020	D - 59	12
156641001	B - 1-7	4
156946021	D - 1	10
156948021	D - 3	10
156950120	D - 5-1	10
156951021	D - 5-2	10
156952021	D - 8	10
156953021	D - 8-1	10
156954021	D - 9	10
156955021	D - 9-1	10
156956021	D - 10	10
156957020	D - 12	10
156958021	D - 14	10
156966121	D - 19	10

